

REGISTRATION SHEET

Please return this sheet by fax or mail when you receive this manual,
so we can inform you of updates as they become available.

Rosetta Hardscapes, LLC
05481 US-31 South
Charlevoix MI 49720
Fax: 231.237.9656
info@discoverrosetta.com

Company Name: _____

Contact Person: _____

Address: _____

Telephone: _____ **Cell:** _____

Fax: _____

E-Mail: _____

Fax to: 231.237.9656



Greetings Specifier / Designer:

Thank you for your interest in Rosetta Hardscapes. This innovative new line of hardscape products combines the rugged subtlety of natural weathered outcropping stone with the installation efficiency and the engineered security of interlocking, dimensional concrete blocks. I would like to give you a brief introduction to our product line, as well as our philosophy used in creating this exciting line of hardscapes.

Rosetta Hardscapes is the industry leader in creating engineered natural looking outdoor landscape with elements that have efficient engineered properties. We can obtain the look and feel of natural stone out cropping without the waste, inefficiency and cost of installing natural stone.

As you read through this manual you will notice that we can optimize the use of Geogrid by not being restricted to any particular horizontal row of stone. This also allows the use of variable height blocks in the wall. We offer standard colors that are indigenous to the area as well as custom colors for select projects. Our design software takes the guess work out of the field installation.

Our Business Philosophy is founded on the following four cornerstones:

Quality:

We believe in long-term excellence, attention to detail, and the use of the best quality material available for a winning combination.

Creativity:

We believe in listening to the market place and leading the industry by creating innovative ways of unlocking the natural beauty around us.

Procedure:

Efficiency in manufacturing, engineering, and installation are the driving forces behind the design of all our products.

Service:

Our goal is to be number one in the industry in servicing the needs of our customers through training, equipping, and listening to our customer's needs.

We look forward to serving you in meeting your needs in the future.

Respectfully yours,

A handwritten signature in black ink, appearing to read "Jim Manthei".

Jim Manthei
President





WALLS

SPECIFICATION FOR ROSETTA® HARDSCAPES WALL SYSTEM

PART 1: GENERAL

1.1 Scope

Work includes furnishing and installing concrete retaining wall units to the lines and grades designated on the construction drawings and as specified herein.

1.2 Reference Standards

ASTM C33 Concrete Aggregates
 ASTM C94 Ready-Mixed Concrete
 ASTM C140 Standard Test Methods for Sampling and Testing Concrete Masonry Units and Related Units
 ASTM C1372 Segmental Retaining Wall Units

1.3 Delivery, Storage, and Handling

- A. Contractor shall check the materials upon delivery to assure proper material has been received.
- B. Contractor shall prevent excessive mud, wet cement and like materials from coming in contact with the SRW units.
- C. Contractor shall protect the materials from damage. Damaged material shall not be incorporated in the project.

PART 2: MATERIALS

2.1 Wall Units

- A. Wall units shall be Rosetta Hardscapes® as produced by a licensed manufacturer.
- B. Wall units shall have Rosetta Hardscapes® block specifications and be made from wet cast concrete in accordance with the following chart:

Climate (Weathering Regions per ASTM C33)	Air Content	28 Day Compressive Strength <i>psi (MPa)</i>	Slump* <i>in (cm)</i>	Min. Concrete Temp. at Placement <i>°F (°C)</i>
Negligible	1½%-4½%	4000 (27.6)	3 to 5 (7.6 to 10.2)	50 (10)
Moderate	3%-6%	4000 (27.6)	3 to 5 (7.6 to 10.2)	50 (10)
Severe	4½%-7½%	4000 (27.6)	3 to 5 (7.6 to 10.2)	50 (10)

All Rosetta Hardscapes products shall use frost-free aggregate.

*Higher slumps are allowed if achieved by use of appropriate admixtures.

Notwithstanding anything stated above, all material used in the wall units must meet applicable ASTM and local requirements for exterior concrete.

- C. Exterior block dimensions, as measured in accordance with ASTM C140, shall be uniform and consistent. Maximum dimensional deviations shall be 0.125 inch (3.2 mm) or 2%, whichever is less, excluding the architectural surface. Maximum width (face to back) deviation including the architectural surface shall be 1.0 inch (2.5 cm).
- D. Exposed faces shall have a textured finish. Other surfaces to be smooth form type. Dime-size bug holes on the block face may be patched and/or shake-on color stain can be used to blend into the remainder of the block face.
- E. Shear heels shall be intact and free from cracks or other defects.

2.2 Leveling Pad and Free Draining Backfill

- A. Leveling pad shall be crushed stone. A drain with gravity outlet shall be placed in the bottom of the stone leveling pad.
- B. Free Draining Backfill material shall be washed stone, shall be placed to a minimum of 1 foot (0.30 m) width behind the back of the wall, and shall extend vertically from the Leveling Pad to an elevation 4 inches (10.2 cm) below the top of wall.
- C. Backfill material shall be approved by the geotechnical engineer. Site excavated soils may be used if approved unless otherwise specified in the drawings. Unsuitable soils with a PI>6, organic soils and frost susceptible soils shall not be used within a 1 to 1 influence area.
- D. Non-woven geotextile fabric shall be placed between the back of the Rosetta blocks and the free draining backfill. Additional non-woven geotextile fabric shall be placed between the Free Draining Backfill and retained soil if required in the detailed wall design.
- E. Where additional fill is needed, Contractor shall submit sample and specifications to the Engineer for approval.

2.3 Drainage

- A. Internal and external drainage shall be evaluated by the Professional Engineer who is responsible for the final wall design.

PART 3: CONSTRUCTION OF WALL SYSTEM

3.1 Excavation

- A. Contractor shall excavate to the lines and grades shown on the construction drawings.

February 26, 2008

SPECIFICATION FOR ROSETTA HARDSCAPES® WALL SYSTEM

3.2 Foundation Soil Preparation

- A. Native foundation soil shall be compacted to 95% of standard proctor or 90% of modified proctor prior to placement of the leveling pad material.
- B. In-situ foundation soil shall be examined by the geotechnical engineer to ensure that the actual foundation soil strength meets or exceeds assumed design strength. Soil not meeting the required strength shall be removed and replaced with acceptable, compacted material.

3.3 Leveling Pad Placement

- A. Leveling Pad shall be placed as shown on the construction drawings.
- B. Leveling Pad shall be placed on undisturbed native soils or suitable replacements fills as directed by the geotechnical engineer.
- C. Leveling Pad shall be compacted to 95% of standard proctor or 90% of modified proctor to ensure a level, hard surface on which to place the first course blocks. Pad shall be constructed to the proper elevation to ensure the final elevation shown on the plans.
- D. Leveling Pad shall have a 6 inch (15.2 cm) minimum depth or deeper as designed by the Professional Engineer responsible for the wall. Pad dimensions shall extend beyond the blocks in all directions to a distance at least equal to the depth of the pad or as designed by the Engineer.
- E. For steps and pavers, a minimum of 1 to 1 ½ inches (2.5 to 3.8 cm) of free draining sand shall be screeded smooth to act as a placement bed for the steps or pavers.

3.4 Unit Installation

- A. The first course of wall units shall be placed on the prepared Leveling Pad with the aesthetic surface facing out and the back edges tight together. All units shall be checked for level and alignment as they are placed. Rosetta blocks shall be placed with the back of the blocks offset from the back of wall reference line based on their unit height. A 6 inch (15.2 cm) high Rosetta block shall be offset 4.5 inches (11.4 cm) from the reference line, a 12 inch (30.5 cm) high Rosetta block shall be offset 3 inches (7.6 cm) from the reference line, an 18 inch (45.7 cm) high Rosetta block shall be offset 1.5 inches (3.8 cm) from the reference line, and a 24 inch (61.0 cm) high Rosetta block shall be set with the back of the block flush with the reference line.
- B. Ensure that units are in full contact with Leveling Pad. Proper care shall be taken to

develop straight lines and smooth curves on base course as per wall layout.

- C. The backfill in front and back of entire base row shall be placed and compacted to firmly lock them in place. Check all units again for level and alignment. All excess material shall be swept from top of units.
- D. Install next course of wall units on top of base row. Position blocks to be offset from seams of blocks below. Blocks shall be placed fully forward so shear heels and back of lower block are engaged. Check each block for proper alignment and level. Backfill to a 12 inch (30.5 cm) width behind the block with Free Draining Backfill. Spread backfill in uniform lifts not exceeding 8 inches (20.3 cm). Employ methods using lightweight compaction equipment that will not disrupt the stability or batter of the wall. Hand-operated plate compaction equipment shall be used around the block and within 3 feet (0.91 m) of the wall to achieve consolidation. Compact backfill to 95% of standard proctor (ASTM D 698, AASHTO T-99) density within 2% of its optimum moisture content.
- E. Install each subsequent course in like manner. Repeat procedure to the extent of wall height.
- F. Allowable construction tolerance at the wall face is 2 degrees vertically, 3 inch (7.6 cm) maximum, and 1 inch in 10 feet (2.5 cm in 3.05 m) horizontally.
- G. All walls shall be installed in accordance with local building codes and requirements.

3.5 Geogrid Installation

- A. See Wall Installation instructions.

PART 4: AVAILABILITY

Rosetta Hardscapes® LLC
05481 South US-31,
Charlevoix, MI 49720
1-877-777-6558
www.discoverrosetta.com
info@discoverrosetta.com

Engineering Assumptions

The gravity wall and reinforced wall charts shown on the following pages are based on our understanding of the concepts and principles for the design of segmental retaining walls as described in the National Concrete Masonry Association (NCMA) *Design Manual for Segmental Retaining Walls, Second Edition*. The design calculations used to derive these charts are available upon request. These charts are not intended to be used for actual construction and all final designs for construction purposes must be performed by a registered professional engineer qualified to design segmental retaining wall structures, using the actual conditions of the proposed site. Many other design applications that are not specifically shown in these charts may also be possible. Contact your local engineer to determine the suitability of Rosetta Hardscapes blocks on unique sites.

Assumed Criteria for Chart Calculations

- Soil friction angles (Φ) of 28°, 30°, and 34° as noted.
- **Global stability has not been considered.** It is recommended that a local engineer compute and apply all local conditions and factors, including global stability, to the site-specific wall design.
- Testing of the Rosetta Hardscapes block interface shear and connection between the Rosetta Hardscapes blocks and Paraweb 30 geosynthetic strap was completed by Bathurst, Clarabut Geotechnical Testing, Inc. Test reports are available upon request.
- Gravity wall sections were analyzed based on a 12" high x 5.5' long (0.305 m x 1.676 m) block.
- Interface shear values were based on the 12" high x 6' long (0.305 m x 1.829 m) block.
- Reinforced wall sections are designed with geogrid to provide the main soil reinforcement and individual Paraweb straps to hold the facing blocks into the reinforced soil mass.
- Paraweb strap lengths are calculated to hold a 12" high x 6' long (0.305 m x 1.829 m) block in place. The longest required strap is used on all blocks in a reinforced wall.

Factors of Safety

Wall Sliding Resistance =	1.5
Wall Overturning =	1.5 – Non Reinforced, 2.0 - Reinforced
Wall Bearing Capacity =	2.0

Material Assumptions

Unit Weight of Concrete =	145 pcf (22.8 kN/m ³)
Minimum Concrete Compressive Strength =	4,000 psi (27.6 MPa)
Moist Soil Unit Weight =	120 pcf (18.9 kN/m ³)

These assumptions were made to provide Rosetta Hardscapes LLC with an approximate retaining wall height. These wall heights were calculated using the assumed material properties and may vary from location to location depending on the soil properties. **For this reason, all final designs for construction purposes must be performed by a registered professional engineer qualified to design segmental retaining wall structures, using the actual conditions of the proposed site.**

February 26, 2008

Commercially Available Engineering Resources

NCMA Design Manual for Segmental Retaining Walls (SRW), 2nd Edition, National Concrete Masonry Association, 13750 Sunrise Valley Drive, Herndon, Virginia 20171-4662 (703) 713-1900
Available at www.ncma.org

NCMA Design Software for Segmental Retaining Walls – SRWall
SRW design for both conventional gravity and soil reinforced walls with simple geometry. Excludes overall stability analysis.
Available at www.ncma.org

MSEW (Mechanically Stabilized Earth Walls) by ADAMA Engineering, Inc.
MSEW will handle more complex loading and wall geometry, including tiered walls. MSEW follows AASHTO and FHWA guidelines.
Available at www.msew.com

ReSSA (Reinforced Soil Slope Analysis) by ADAMA Engineering, Inc.
Global stability analysis to assess the rotation and translational stability of slopes.
Available at www.msew.com

January 4, 2008

ROSETTA® HARDSCAPES LLC - AVERAGE BLOCK PROPERTIES

12" (30.5 cm) HIGH BLOCKS

12" x 3' (30.5 cm x 91.4 cm) BLOCK



Height = 12.0" (30.5 cm)
Width = 17.4" (44.2 cm)
Length = 35.5" (90.2 cm)
Block Setback = 3.0" (7.6 cm)

Volume = 4.279 cft (0.121 m³)
Weight = 620 lbs (281 kg)
Center of Gravity = 8.7" (22.1 cm)

12" x 3.5' (30.5 cm x 106.7 cm) BLOCK



Height = 12.0" (30.5 cm)
Width = 18.2" (46.2 cm)
Length = 40.9" (103.9 cm)
Block Setback = 3.0" (7.6 cm)

Volume = 5.168 cft (0.146 m³)
Weight = 749 lbs (340 kg)
Center of Gravity = 9.4" (23.9 cm)

12" x 4' (30.5 cm x 121.9 cm) BLOCK



Height = 12.0" (30.5 cm)
Width = 18.6" (47.2 cm)
Length = 47.8" (121.4 cm)
Block Setback = 3.0" (7.6 cm)

Volume = 6.162 cft (0.174 m³)
Weight = 893 lbs (405 kg)
Center of Gravity = 9.5" (24.1 cm)

12" x 4.5' (30.5 cm x 137.2 cm) BLOCK

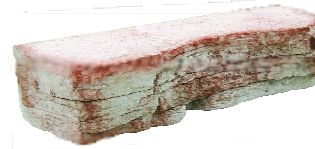

Height = 12.0" (30.5 cm)
Width = 17.6" (44.7 cm)
Length = 53.7" (136.4 cm)
Block Setback = 3.0" (7.6 cm)

Volume = 6.554 cft (0.186 m³)
Weight = 950 lbs (431 kg)
Center of Gravity = 8.9" (22.6 cm)

12" x 5' (30.5 cm x 152.4 cm) BLOCK



Height = 12.0" (30.5 cm)
Width = 18.4" (46.7 cm)
Length = 59.7" (151.6 cm)
Block Setback = 3.0" (7.6 cm)

Volume = 7.604 cft (0.215 m³)
Weight = 1103 lbs (500 kg)
Center of Gravity = 9.8" (24.9 cm)

12" x 5.5' (30.5 cm x 167.6 cm) BLOCK



Height = 11.9" (30.2 cm)
Width = 17.3" (43.9 cm)
Length = 65.8" (167.1 cm)
Block Setback = 3.0" (7.6 cm)

Volume = 7.860 cft (0.223 m³)
Weight = 1140 lbs (517 kg)
Center of Gravity = 9.2" (23.4 cm)

12" x 6' (30.5 cm x 182.9 cm) BLOCK



Height = 11.9" (30.2 cm)
Width = 18.0" (45.7 cm)
Length = 71.7" (182.1 cm)
Block Setback = 3.0" (7.6 cm)

Volume = 8.926 cft (0.253 m³)
Weight = 1294 lbs (587 kg)
Center of Gravity = 9.4" (23.9 cm)

NOTES:

- The block properties shown here are average values of Rosetta® Hardscapes blocks.
- Block weights shown are based on an assumed concrete unit weight of 145 lb/ft³ (22.8 kN/m³).
- Actual weights and volumes may vary.
- Center of gravity shown is measured from the back of the blocks.
- Average block width shown is calculated by dividing the block volume by the length at the back of the block and height at the center of gravity.
- Rosetta® blocks are manufactured with alternating sides up, providing 24 different block faces from the 12 standard retaining wall blocks.

September 2, 2008

ROSETTA® HARDSCAPES LLC - AVERAGE BLOCK PROPERTIES

6" HIGH BLOCKS

6" x 2' (15.2 cm x 61.0 cm) BLOCK



Height = 6.0" (15.2 cm)
Width = 20.6" (52.3 cm)
Length = 24.1" (61.2 cm)
Block Setback = 1.5" (3.8 cm)

Volume = 1.725 cft (0.049 m³)
Weight = 250 lbs (113 kg)
Center of Gravity = 11.0" (27.9 cm)

6" x 3' (15.2 cm x 91.4 cm) BLOCK



Height = 6.0" (15.2 cm)
Width = 17.9" (45.5 cm)
Length = 35.8" (90.9 cm)
Block Setback = 1.5" (3.8 cm)

Volume = 2.244 cft (0.064 m³)
Weight = 324 lbs (147 kg)
Center of Gravity = 9.5" (24.1 cm)

6" x 4' (15.2 cm x 121.9 cm) BLOCK



Height = 6.0" (15.2 cm)
Width = 18.3" (46.5 cm)
Length = 48.0" (121.9 cm)
Block Setback = 1.5" (3.8 cm)

Volume = 3.053 cft (0.086 m³)
Weight = 442 lbs (200 kg)
Center of Gravity = 9.8" (24.9 cm)

18" HIGH BLOCK

18" x 5' (45.7 cm x 152.4 cm) BLOCK



Height = 18.0" (45.7 cm)
Width = 18.2" (46.2 cm)
Length = 59.5" (151.1 cm)
Block Setback = 4.5" (11.4 cm)

Volume = 11.266 cft (0.319 m³)
Weight = 1633 lbs (741 kg)
Center of Gravity = 9.6" (24.4 cm)

24" HIGH BLOCK

24" x 4' (61.0 cm x 121.9 cm) BLOCK



Height = 24.0" (61.0 cm)
Width = 18.9" (48.0 cm)
Length = 47.4" (120.4 cm)
Block Setback = 6.0" (15.2 cm)

Volume = 12.420 cft (0.352 m³)
Weight = 1801 lbs (817 kg)
Center of Gravity = 9.9" (25.1 cm)

NOTES:

- The block properties shown here are average values of Rosetta® Hardscapes blocks.
- Block weights shown are based on an assumed concrete unit weight of 145 lb/ft³ (22.8 kN/m³).
- Actual weights and volumes may vary.
- Center of gravity shown is measured from the back of the blocks.
- Average block width shown is calculated by dividing the block volume by the length at the back of the block and height at the center of gravity.
- Rosetta® blocks are manufactured with alternating sides up, providing 24 different block faces from the 12 standard retaining wall blocks.

September 2, 2008



PROJECT:
Engineering Calculation Highlights

SHEET:
1 of 2

PREPARED BY:
Rosetta Hardscapes, LLC

DATE:
03-03-08

This sheet highlights some of the design values used to prepare the Preliminary Rosetta Wall Height Guide charts. It is intended to serve as reference information for Design Professionals only. Wall design requires a detailed understanding of engineering concepts, and must be prepared by a Licensed Professional Engineer.

DESIGN BLOCK

Gravity walls were analyzed based on a 12" high x 5.5' long block. For the gravity walls in the preliminary height guides, wall sliding was the controlling criteria. The 12" x 5.5' block has the smallest average block width and yields the lowest available wall heights to resist sliding. Since Rosetta blocks come in 6" height increments, the block height, weight, and setback values for the 12" x 5.5' block were halved to represent an equivalent 6" block for analysis.

$$\begin{aligned}
 h_{\text{block}} &= 6" & W_{\text{block}} &= 17.3" \text{ (average width)} \\
 L_{\text{block}} &= 65.8" & G_u &= 8.1" \text{ (from theoretical toe)} \\
 \text{Weight} &= 573 \text{ lbs} & \text{Block Setback} &= 1.5" \text{ horizontal/6" vertical, } \omega = 14.0^\circ
 \end{aligned}$$

INTERFACE SHEAR

(See the testing report for the 12" x 3' Rosetta block prepared by Bathurst Clarabut Geotechnical Testing, Inc.) The 12" x 6' Rosetta block has the smallest shear heel area per wall face (5.7 in² shear area / ft² wall face - see table below) of all Rosetta blocks. It has half the shear area per wall face as the 12"x3' block, and is assumed to have half the interface shear capacity of the 12" x 3' block. Since Rosetta blocks come in 6" height increments, the capacity of the 12"x6' block was halved (again) to represent an equivalent 6" block for analysis.

$$V_u = 360 + N \tan 26^\circ \leq 1000 \text{ lb/ft}$$

BLOCK (Block Size)	SHEAR HEEL (Number / Size)	WALL FACE (ft ²)	SHEAR AREA / WALL FACE (in ² / ft ²)
6" x 2'	(1) 15.5	1.0	15.5
6" x 3'	(1) 23.0	1.5	15.3
6" x 4'	(1) 35.0	2.0	17.5
12" x 3'	(2) 17.1	3.0	11.4
12" x 3.5'	(2) 17.1	3.5	9.7
12" x 4'	(2) 17.1	4.0	8.5
12" x 4.5'	(2) 17.1	4.5	7.6
12" x 5'	(2) 17.1	5.0	6.8
12" x 5.5'	(2) 17.1	5.5	6.2
12" x 6'	(2) 17.1	6.0	5.7
18" x 5'	(2) 27.6	7.5	7.3
24" x 4'	(2) 23.5	8.0	5.8

This sheet highlights some of the design values used to prepare the Preliminary Rosetta Wall Height Guide charts. It is intended to serve as reference information for Design Professionals only. Wall design requires a detailed understanding of engineering concepts, and must be prepared by a Licensed Professional Engineer.

PARAWEB STRAP DESIGN

Paraweb strap is designed to hold the individual facing blocks into a reinforced soil mass. The capacity of the strap to resist pullout is set equal to the force acting on the block times a factor of safety, ($R_{po} = F_{po} \times F.S.$). The resulting equation is solved for the minimum required length of strap embedment:

$$l_e = [K_{ah} \times \sigma_n (\text{DL and LL}) \times A_{\text{block}} \times F.S.] / [C_i \times W_s \times 2 \text{ legs/hook} \times 2 \text{ sides/leg} \times \sigma_n (\text{DL only}) \times \tan \phi_i]$$

Additional strap is required to insure l_e is located beyond a local failure surface between geogrid layers. The length of strap in the active zone, l_a is calculated by:

$$l_a = \text{geogrid layer vertical spacing} / \tan \alpha_i \quad (\alpha_i \text{ is the angle of the Coulomb failure surface})$$

The strap required for each block is the sum of the embedment and active lengths, $l_{min} = l_e + l_a$
For typical construction, the longest required strap length is used on all blocks in the wall.

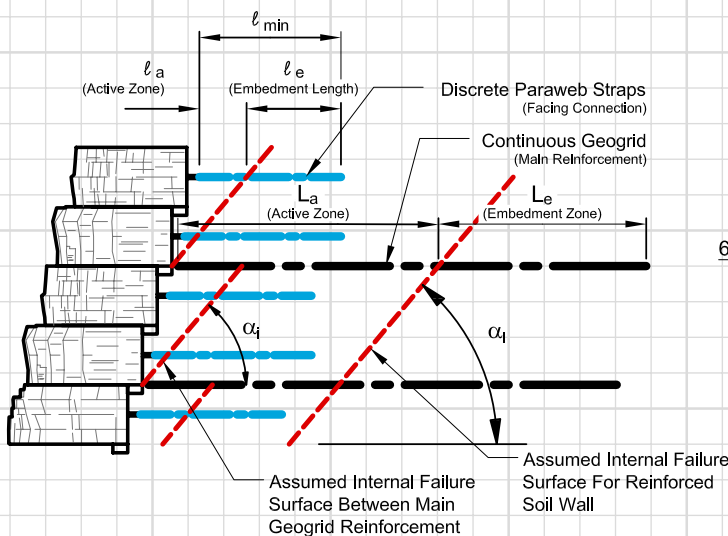

TYPICAL COMPONENTS - SECTION VIEW

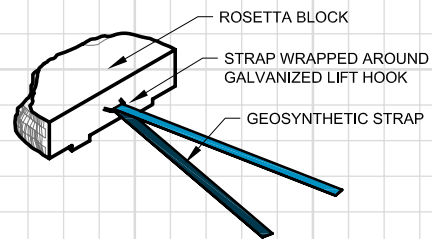

6" OR 12" HIGH ROSETTA BLOCKS

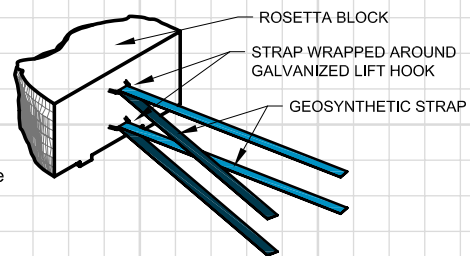

18" OR 24" HIGH ROSETTA BLOCKS

PARAWEB STRAP CONNECTION

(See the testing report prepared by Bathurst Clarabut Geotechnical Testing, Inc.) In testing, the connection between Paraweb 30 Strap and the Rosetta blocks failed in strap rupture between 85% and 98% of the index tensile strength times two (2 legs/hook) of the strap.

Connection capacity, $T_c = 0.85 \times T_{ult} \times 2 / F.S. = 0.85 \times 6750 \times 2 / 1.5 = 7,650 \text{ lb}$

The 12"x6' block has the greatest face area per connection, resulting in the smallest available connection strength. As such, the connection strength of the 12"x6' block is used for analysis.

$$T_c = 6,750 \text{ lb} / 6 \text{ ft} = 1,275 \text{ lb/ft}$$

GRAVITY

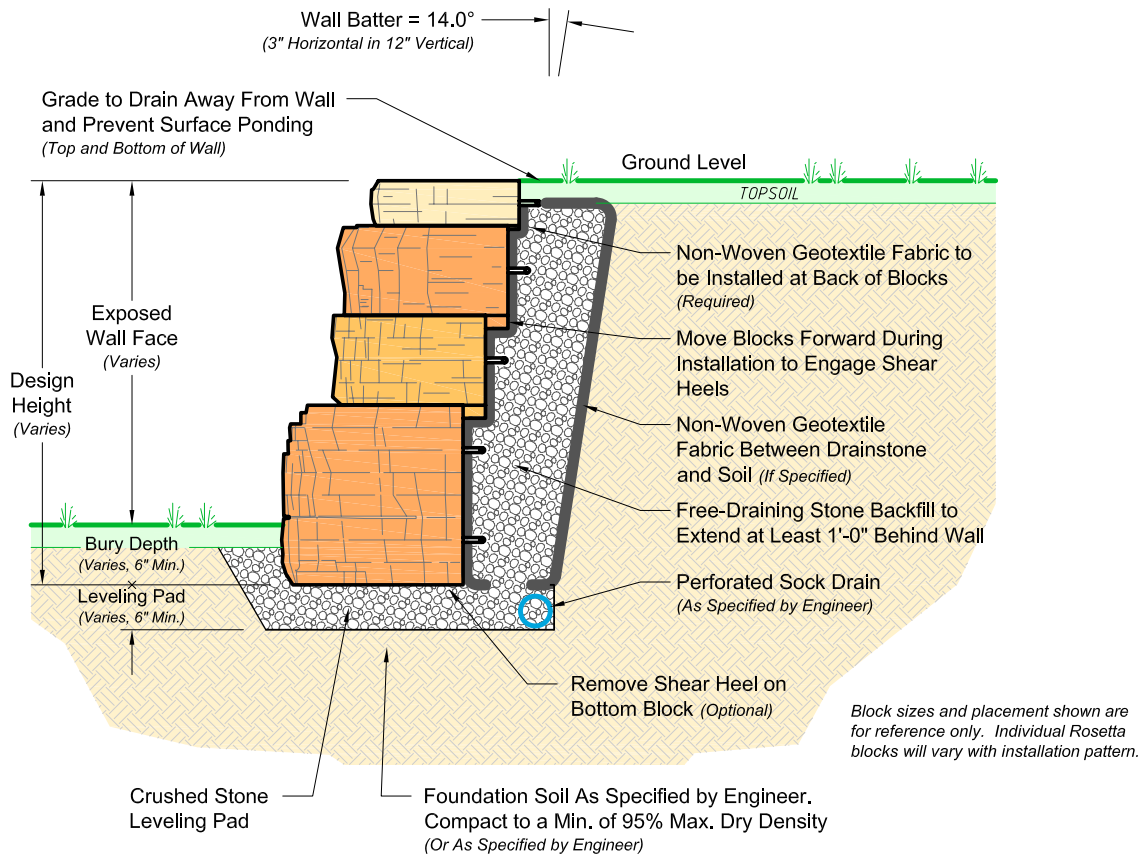

TYPICAL GRAVITY WALL SECTION
(NO SCALE)

DRAWN BY: J. Johnson	TITLE: TYPICAL ROSETTA HARDSCAPES GRAVITY WALL	 05481 US 31 SOUTH CHARLEVOIX, MI 49720 877-777-6558 • 231-237-9656 Fax • www.discoverrosetta.com
APPROVED BY:		
DATE: January 25, 2008	DRAWING FILE: Gravity Wall - Typical Section.dwg	

ROSETTA® HARDSCAPES LLC - PRELIMINARY WALL HEIGHT GUIDE

Dense Well-Graded Sand, Sand and Gravel with an Internal Angle of Friction (ϕ) = 34°

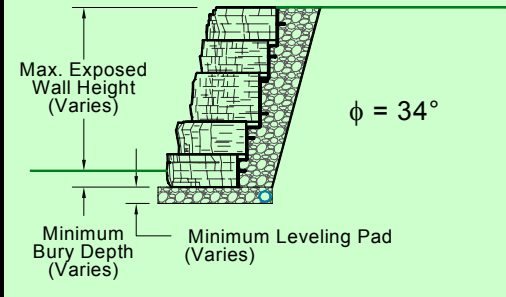
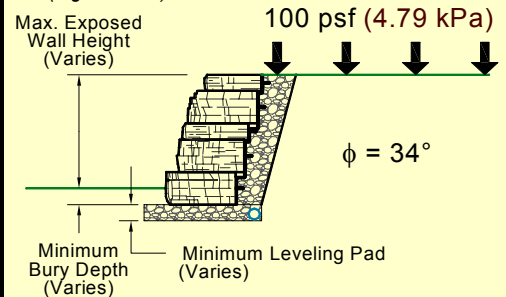
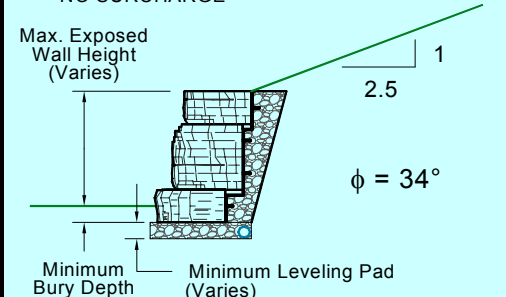
Wall Loading Condition	Design Height ft (m)	Minimum Bury Depth ft (m)	Minimum Leveling Pad ft (m)	Max. Exposed Wall Height ft (m)
<ul style="list-style-type: none"> • NO BACKSLOPE • NO SURCHARGE  <p>$\phi = 34^\circ$</p>	2.0 (0.61)	0.5 (0.15)	0.5 (0.15)	1.5 (0.46)
	3.0 (0.91)	0.5 (0.15)	0.5 (0.15)	2.5 (0.76)
	4.0 (1.22)	0.5 (0.15)	0.5 (0.15)	3.5 (1.07)
	5.0 (1.52)	0.5 (0.15)	0.5 (0.15)	4.5 (1.37)
	6.0 (1.83)	0.5 (0.15)	0.5 (0.15)	5.5 (1.68)
<ul style="list-style-type: none"> • NO BACKSLOPE • 100 psf (4.79 kPa) LIVE LOAD SURCHARGE (Light Traffic)  <p>100 psf (4.79 kPa)</p> <p>$\phi = 34^\circ$</p>	2.0 (0.61)	0.5 (0.15)	0.5 (0.15)	1.5 (0.46)
	3.0 (0.91)	0.5 (0.15)	0.5 (0.15)	2.5 (0.76)
	4.0 (1.22)	0.5 (0.15)	0.5 (0.15)	3.5 (1.07)
	5.0 (1.52)	0.5 (0.15)	0.5 (0.15)	4.5 (1.37)
	6.0 (1.83)	0.5 (0.15)	0.5 (0.15)	5.5 (1.68)
<ul style="list-style-type: none"> • 1:2.5 (21.8°) BACKSLOPE • NO SURCHARGE  <p>1 2.5</p> <p>$\phi = 34^\circ$</p>	2.0 (0.61)	0.5 (0.15)	0.5 (0.15)	1.5 (0.46)
	3.0 (0.91)	0.5 (0.15)	0.5 (0.15)	2.5 (0.76)
	4.0 (1.22)	0.5 (0.15)	0.5 (0.15)	3.5 (1.07)
	5.0 (1.52)	0.5 (0.15)	0.5 (0.15)	4.5 (1.37)
	6.0 (1.83)	0.5 (0.15)	0.5 (0.15)	5.5 (1.68)

NOTES The above chart was prepared by Rosetta® Hardscapes LLC for estimating and conceptual design purposes only. All information is believed to be true and accurate, however, Rosetta® Hardscapes LLC assumes no responsibility for the use of these design charts for actual construction. Determination of the suitability of each chart is the sole responsibility of the user. **Final designs for construction purposes must be performed by a registered Professional Engineer**, using the actual conditions of the proposed site.

1. Unit weight of 28°, 30°, 34° and 40° soils is assumed to be 120 pcf (18.9 kN/m³).
2. Minimum factors of safety are 1.5 for sliding, 1.5 for overturning and 2.0 for bearing capacity.
3. Designs are in general accordance with NCMA's *Design Manual for Segmental Retaining Walls (2nd ed.)*.
4. **Global stability has not been addressed in these charts.**
5. The wall design shall address both internal and external drainage and shall be evaluated by the Professional Engineer who is responsible for the final wall design.
6. Backfill material to be compacted to 95% standard proctor.
7. All Rosetta® Hardscapes LLC Wall System Specifications are to be followed.
8. Block sizes and placement shown for reference only. Individual Rosetta® Hardscapes blocks will vary with installation pattern.

May 30, 2008

ROSETTA® HARDSCAPES LLC - PRELIMINARY WALL HEIGHT GUIDE

Silty Sand, Fine to Medium Sand with an Internal Angle of Friction (ϕ) = 30°

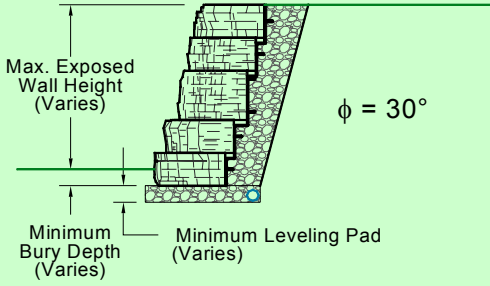
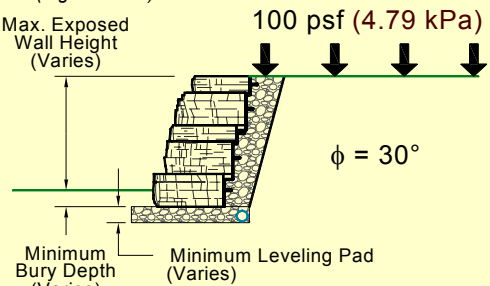
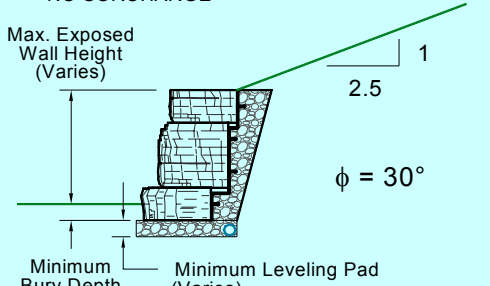
Wall Loading Condition	Design Height		Minimum Bury Depth		Minimum Leveling Pad		Max. Exposed Wall Height	
	ft	(m)	ft	(m)	ft	(m)	ft	(m)
<ul style="list-style-type: none"> • NO BACKSLOPE • NO SURCHARGE  <p style="text-align: right;">$\phi = 30^\circ$</p>	2.0	(0.61)	0.5	(0.15)	0.5	(0.15)	1.5	(0.46)
	3.0	(0.91)	0.5	(0.15)	0.5	(0.15)	2.5	(0.76)
	4.0	(1.22)	0.5	(0.15)	0.5	(0.15)	3.5	(1.07)
	5.0	(1.52)	0.5	(0.15)	0.5	(0.15)	4.5	(1.37)
	6.0	(1.83)	0.5	(0.15)	0.5	(0.15)	5.5	(1.68)
<ul style="list-style-type: none"> • NO BACKSLOPE • 100 psf (4.79 kPa) LIVE LOAD SURCHARGE (Light Traffic)  <p style="text-align: center;">100 psf (4.79 kPa)</p> <p style="text-align: right;">$\phi = 30^\circ$</p>	2.0	(0.61)	0.5	(0.15)	0.5	(0.15)	1.5	(0.46)
	3.0	(0.91)	0.5	(0.15)	0.5	(0.15)	2.5	(0.76)
	4.0	(1.22)	0.5	(0.15)	0.5	(0.15)	3.5	(1.07)
<ul style="list-style-type: none"> • 1:2.5 (21.8°) BACKSLOPE • NO SURCHARGE  <p style="text-align: right;">$\phi = 30^\circ$</p>	2.0	(0.61)	0.5	(0.15)	0.5	(0.15)	1.5	(0.46)
	3.0	(0.91)	0.5	(0.15)	0.5	(0.15)	2.5	(0.76)
	4.0	(1.22)	0.5	(0.15)	0.5	(0.15)	3.5	(1.07)

NOTES The above chart was prepared by Rosetta® Hardscapes LLC for estimating and conceptual design purposes only. All information is believed to be true and accurate, however, Rosetta® Hardscapes LLC assumes no responsibility for the use of these design charts for actual construction. Determination of the suitability of each chart is the sole responsibility of the user. **Final designs for construction purposes must be performed by a registered Professional Engineer**, using the actual conditions of the proposed site.

1. Unit weight of 28°, 30°, 34° and 40° soils is assumed to be 120 pcf (18.9 kN/m³).
2. Minimum factors of safety are 1.5 for sliding, 1.5 for overturning and 2.0 for bearing capacity.
3. Designs are in general accordance with NCMA's *Design Manual for Segmental Retaining Walls (2nd ed.)*.
4. **Global stability has not been addressed in these charts.**
5. The wall design shall address both internal and external drainage and shall be evaluated by the Professional Engineer who is responsible for the final wall design.
6. Backfill material to be compacted to 95% standard proctor.
7. All Rosetta® Hardscapes LLC Wall System Specifications are to be followed.
8. Block sizes and placement shown for reference only. Individual Rosetta® Hardscapes blocks will vary with installation pattern.

May 30, 2008

ROSETTA® HARDSCAPES LLC - PRELIMINARY WALL HEIGHT GUIDE

Silty Sand, Clayey Sand with an Internal Angle of Friction (ϕ) = 28°

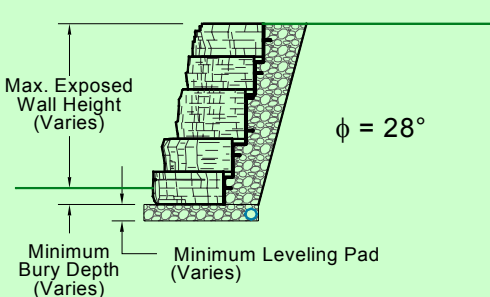
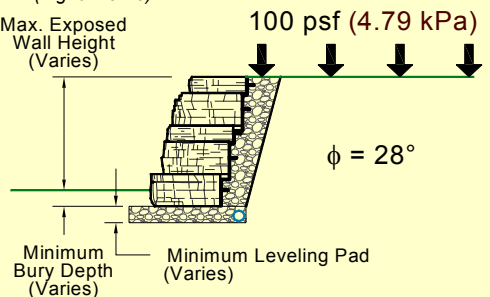
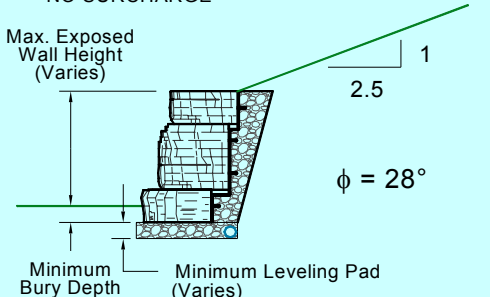
Wall Loading Condition	Design Height ft (m)	Minimum Bury Depth ft (m)	Minimum Leveling Pad ft (m)	Max. Exposed Wall Height ft (m)
<ul style="list-style-type: none"> • NO BACKSLOPE • NO SURCHARGE  <p>$\phi = 28^\circ$</p>	2.0 (0.61)	0.5 (0.15)	0.5 (0.15)	1.5 (0.46)
	3.0 (0.91)	0.5 (0.15)	0.5 (0.15)	2.5 (0.76)
	4.0 (1.22)	0.5 (0.15)	0.5 (0.15)	3.5 (1.07)
	5.0 (1.52)	0.5 (0.15)	0.5 (0.15)	4.5 (1.37)
<ul style="list-style-type: none"> • NO BACKSLOPE • 100 psf (4.79 kPa) LIVE LOAD SURCHARGE (Light Traffic)  <p>100 psf (4.79 kPa)</p> <p>$\phi = 28^\circ$</p>	2.0 (0.61)	0.5 (0.15)	0.5 (0.15)	1.5 (0.46)
	3.0 (0.91)	0.5 (0.15)	0.5 (0.15)	2.5 (0.76)
	4.0 (1.22)	0.5 (0.15)	0.5 (0.15)	3.5 (1.07)
<ul style="list-style-type: none"> • 1:2.5 (21.8°) BACKSLOPE • NO SURCHARGE  <p>1 2.5</p> <p>$\phi = 28^\circ$</p>	2.0 (0.61)	0.5 (0.15)	0.5 (0.15)	1.5 (0.46)
	3.0 (0.91)	0.5 (0.15)	0.5 (0.15)	2.5 (0.76)
	4.0 (1.22)	0.5 (0.15)	0.5 (0.15)	3.5 (1.07)

NOTES The above chart was prepared by Rosetta® Hardscapes LLC for estimating and conceptual design purposes only. All information is believed to be true and accurate, however, Rosetta® Hardscapes LLC assumes no responsibility for the use of these design charts for actual construction. Determination of the suitability of each chart is the sole responsibility of the user. **Final designs for construction purposes must be performed by a registered Professional Engineer**, using the actual conditions of the proposed site.

- Unit weight of 28°, 30°, 34° and 40° soils is assumed to be 120 pcf (18.9 kN/m³).
- Minimum factors of safety are 1.5 for sliding, 1.5 for overturning and 2.0 for bearing capacity.
- Designs are in general accordance with NCMA's *Design Manual for Segmental Retaining Walls (2nd ed.)*.
- Global stability has not been addressed in these charts.**
- The wall design shall address both internal and external drainage and shall be evaluated by the Professional Engineer who is responsible for the final wall design.
- Backfill material to be compacted to 95% standard proctor.
- All Rosetta® Hardscapes LLC Wall System Specifications are to be followed.
- Block sizes and placement shown for reference only. Individual Rosetta® Hardscapes blocks will vary with installation pattern.

May 30, 2008

ROSETTA® HARDSCAPES LLC - PRELIMINARY WALL HEIGHT GUIDE

Crushed Stone Backfill with $(\phi) = 40^\circ$ Over Native Soil with $(\phi) = 28^\circ$

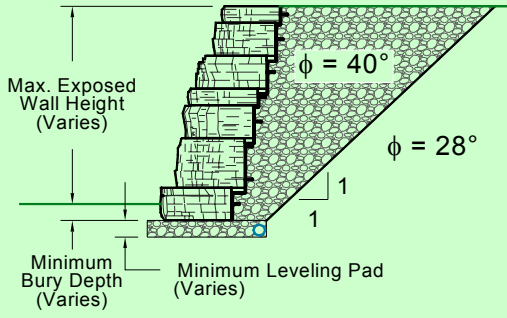
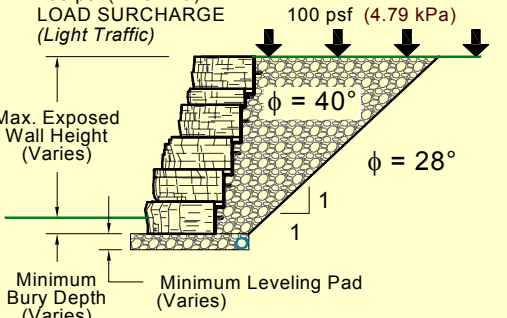
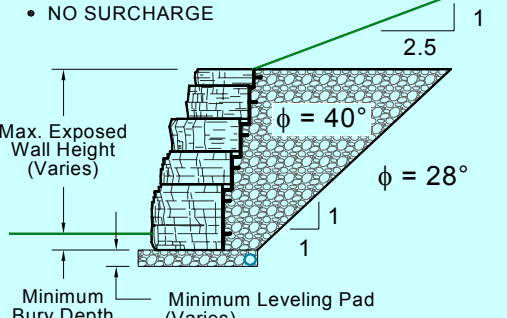
Wall Loading Condition	Design Height		Minimum Bury Depth		Minimum Leveling Pad		Max. Exposed Wall Height	
	ft	(m)	ft	(m)	ft	(m)	ft	(m)
<ul style="list-style-type: none"> • NO BACKSLOPE • NO SURCHARGE 	2.0	(0.61)	0.5	(0.15)	0.5	(0.15)	1.5	(0.46)
	3.0	(0.91)	0.5	(0.15)	0.5	(0.15)	2.5	(0.76)
	4.0	(1.22)	0.5	(0.15)	0.5	(0.15)	3.5	(1.07)
	5.0	(1.52)	0.5	(0.15)	0.5	(0.15)	4.5	(1.37)
	6.0	(1.83)	0.5	(0.15)	0.5	(0.15)	5.5	(1.68)
	7.0	(2.13)	0.5	(0.15)	1.0	(0.30)	6.5	(1.98)
<ul style="list-style-type: none"> • NO BACKSLOPE • 100 psf (4.79 kPa) LIVE LOAD SURCHARGE (Light Traffic) 	2.0	(0.61)	0.5	(0.15)	0.5	(0.15)	1.5	(0.46)
	3.0	(0.91)	0.5	(0.15)	0.5	(0.15)	2.5	(0.76)
	4.0	(1.22)	0.5	(0.15)	0.5	(0.15)	3.5	(1.07)
	5.0	(1.52)	0.5	(0.15)	0.5	(0.15)	4.5	(1.37)
	6.0	(1.83)	0.5	(0.15)	1.0	(0.30)	5.5	(1.68)
<ul style="list-style-type: none"> • 1:2.5 (21.8°) BACKSLOPE • NO SURCHARGE 	2.0	(0.61)	0.5	(0.15)	0.5	(0.15)	1.5	(0.46)
	3.0	(0.91)	0.5	(0.15)	0.5	(0.15)	2.5	(0.76)
	4.0	(1.22)	0.5	(0.15)	0.5	(0.15)	3.5	(1.07)
	5.0	(1.52)	0.5	(0.15)	0.5	(0.15)	4.5	(1.37)
	6.0	(1.83)	0.75	(0.23)	0.5	(0.15)	5.25	(1.60)

NOTES The above chart was prepared by Rosetta® Hardscapes LLC for estimating and conceptual design purposes only. All information is believed to be true and accurate, however, Rosetta® Hardscapes LLC assumes no responsibility for the use of these design charts for actual construction. Determination of the suitability of each chart is the sole responsibility of the user. **Final designs for construction purposes must be performed by a registered Professional Engineer**, using the actual conditions of the proposed site.

1. Unit weight of 28°, 30°, 34° and 40° soils is assumed to be 120 pcf (18.9 kN/m³).
2. Minimum factors of safety are 1.5 for sliding, 1.5 for overturning and 2.0 for bearing capacity.
3. Designs are in general accordance with NCMA's *Design Manual for Segmental Retaining Walls (2nd ed.)*.
4. **Global stability has not been addressed in these charts.**
5. The wall design shall address both internal and external drainage and shall be evaluated by the Professional Engineer who is responsible for the final wall design.
6. Backfill material to be compacted to 95% standard proctor.
7. All Rosetta® Hardscapes LLC Wall System Specifications are to be followed.
8. Block sizes and placement shown for reference only. Individual Rosetta® Hardscapes blocks will vary with installation pattern.

May 30, 2008

NOTES:

- Available Wall Heights Vary Based on Site Specific Conditions.
- Contact your Local Professional Engineer for Final Design for Construction.
- Ends of Wall to Be Turned Into the Bank to Prevent Water Encroachment Around Ends of Wall.

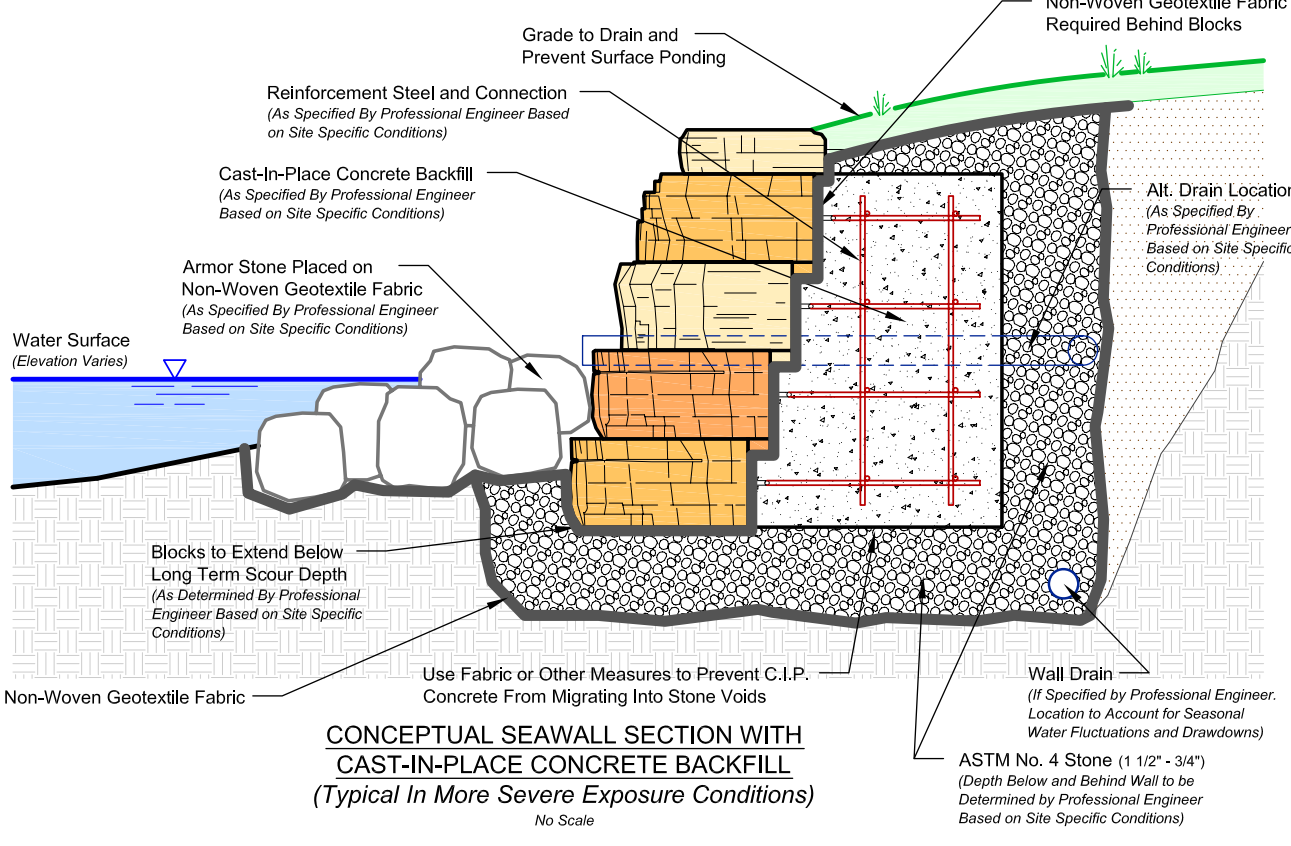
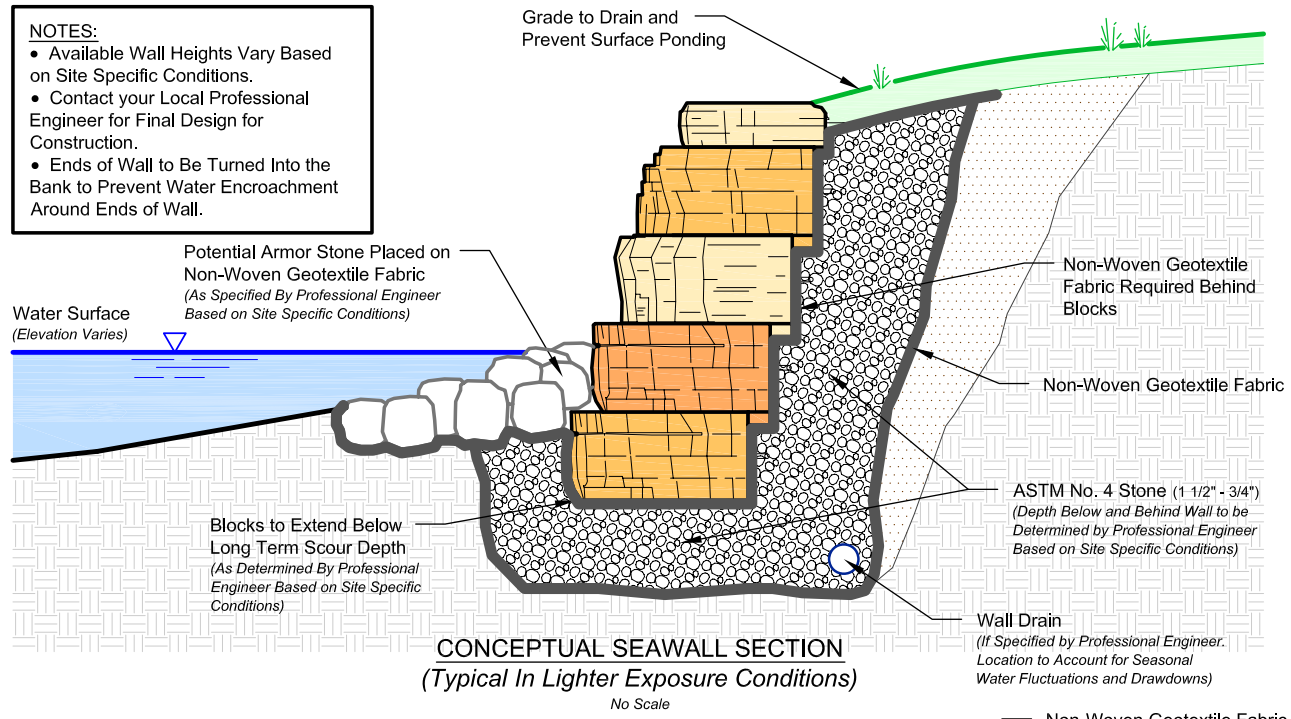

DRAWN BY: J. Johnson	TITLE:
APPROVED BY:	
DATE: 05/08/08	
SHEET NO. : 1 of 1	DRAWING FILE: Seawall - Conceptual Details.dwg

ROSETTA HARDSCAPES
SEAWALL - CONCEPTUAL DETAILS

ROSETTA
HARDSCAPES, LLC
05481 US 31 SOUTH CHARLEVOIX, MI 49720
877-777-6558 • 231-237-9656 Fax • www.discoverrosetta.com

EXTENDED HEIGHT GRAVITY

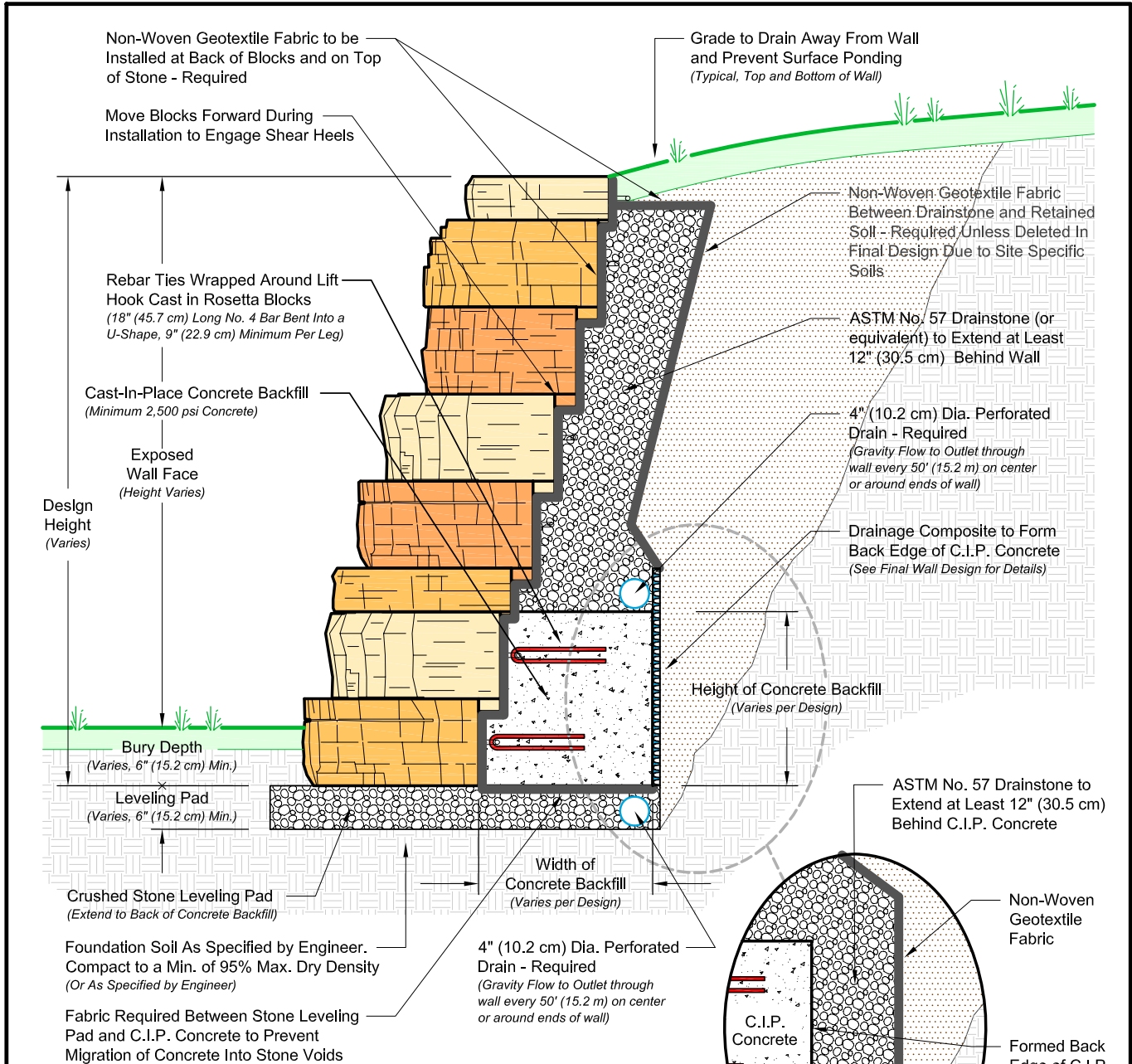

**TYPICAL WALL SECTION WITH
CAST-IN-PLACE CONCRETE BACKFILL**

(NO SCALE)

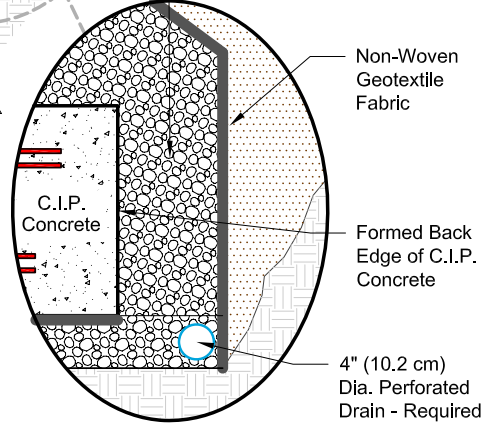

**ALTERNATE DRAIN DETAIL
BEHIND C.I.P. CONCRETE**

(NO SCALE)

- Block sizes and placement shown are for reference only. Individual Rosetta blocks will vary with installation pattern.
- This drawing is conceptual in nature and for general reference only.
- **Final designs for construction must be prepared by a registered Professional Engineer** using the actual conditions of the proposed site.
- **Final wall design must address both internal and external drainage and shall be evaluated by the Professional Engineer who is responsible for the wall design.**

DRAWN BY: J. Johnson	TITLE:
APPROVED BY:	TYPICAL ROSETTA HARDSCAPES GRAVITY WALL WITH CAST-IN-PLACE CONCRETE BACKFILL
DATE: 05/02/08	
SHEET NO. : 1 of 1	

DRAWING FILE:
Concrete Backfill - Typical Section.dwg

ROSETTA
HARDSCAPES, LLC
05481 US 31 SOUTH CHARLEVOIX, MI 49720
877-777-6558 • 231-237-9656 Fax • www.discoverrosetta.com

ROSETTA® HARDSCAPES LLC - PRELIMINARY WALL HEIGHT GUIDE

GRAVITY WALL WITH POURED-IN-PLACE CONCRETE BACKFILL

Dense Well-Graded Sand, Sand and Gravel with an Internal Angle of Friction (ϕ) = 34°

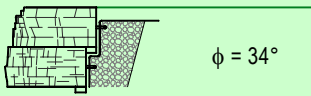
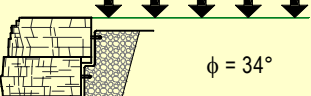
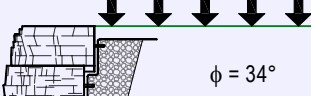
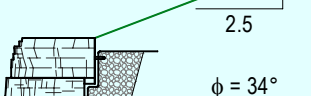
Wall Loading Condition	Design Height ft (m)	Minimum Wall Bury Depth ft (m)	Minimum Leveling Pad Depth ft (m)	Concrete Width Behind Blocks ft (m)	Concrete Height Above Stone ft (m)	Maximum Exposed Wall Height ft (m)
<ul style="list-style-type: none"> • NO BACKSLOPE • NO SURCHARGE  <p>$\phi = 34^\circ$</p>	≤ 6.5 (1.98)	See Preliminary Gravity Charts				
	7.0 (2.13)	0.5 (0.15)	0.5 (0.15)	1.0 (0.30)	1.0 (0.30)	6.5 (1.98)
	8.0 (2.44)	0.5 (0.15)	0.5 (0.15)	1.5 (0.46)	2.0 (0.61)	7.5 (2.29)
	9.0 (2.74)	0.5 (0.15)	0.5 (0.15)	2.0 (0.61)	3.0 (0.91)	8.5 (2.59)
<ul style="list-style-type: none"> • NO BACKSLOPE • 100 psf (4.79 kPa) LIVE LOAD SURCHARGE  <p>$\phi = 34^\circ$</p>	≤ 5.5 (1.68)	See Preliminary Gravity Charts				
	6.0 (1.83)	0.5 (0.15)	0.5 (0.15)	1.0 (0.30)	1.0 (0.30)	5.5 (1.68)
	7.0 (2.13)	0.5 (0.15)	0.5 (0.15)	1.5 (0.46)	2.0 (0.61)	6.5 (1.98)
	8.0 (2.44)	0.5 (0.15)	0.5 (0.15)	2.0 (0.61)	3.0 (0.91)	7.5 (2.29)
<ul style="list-style-type: none"> • NO BACKSLOPE • 250 psf (11.96 kPa) LIVE LOAD SURCHARGE  <p>$\phi = 34^\circ$</p>	4.0 (1.22)	0.5 (0.15)	0.5 (0.15)	1.0 (0.30)	1.0 (0.30)	3.5 (1.07)
	5.0 (1.52)	0.5 (0.15)	0.5 (0.15)	1.5 (0.46)	2.0 (0.61)	4.5 (1.37)
	6.0 (1.83)	0.5 (0.15)	0.5 (0.15)	2.0 (0.61)	3.0 (0.91)	5.5 (1.68)
<ul style="list-style-type: none"> • 1:2.5 (21.8°) BACKSLOPE • NO SURCHARGE  <p>$\phi = 34^\circ$</p>	≤ 5.5 (1.68)	See Preliminary Gravity Charts				
	6.0 (1.83)	0.5 (0.15)	0.5 (0.15)	1.0 (0.30)	1.0 (0.30)	5.5 (1.68)
	7.0 (2.13)	0.5 (0.15)	0.5 (0.15)	1.5 (0.46)	2.0 (0.61)	6.5 (1.98)
	8.0 (2.44)	0.5 (0.15)	0.5 (0.15)	2.0 (0.61)	3.0 (0.91)	7.5 (2.29)

NOTES: The above chart was prepared by Rosetta® Hardscapes LLC for estimating and conceptual design purposes only. All information is believed to be true and accurate, however, Rosetta® Hardscapes LLC assumes no responsibility for the use of these design charts for actual construction. Determination of the suitability of each chart is the sole responsibility of the user. Final designs for construction purposes must be performed by a registered Professional Engineer using the actual conditions of the proposed site.

1. Unit weight of 28°, 30°, 34° and 40° soils is assumed to be 120pcf (18.9 kN/m³).
2. Minimum factors of safety are 1.5 for sliding, 1.5 for overturning and 2.0 for bearing capacity.
3. Global stability has not been addressed in these charts.
4. The wall design shall address both internal and external drainage and shall be evaluated by the Professional Engineer who is responsible for the final wall design.
5. Backfill material to be compacted to 95% standard proctor.
6. All Rosetta® Hardscapes LLC Wall System Specifications are to be followed.
7. Block sizes and placement shown for reference only. Individual Rosetta® Hardscapes blocks will vary with installation pattern.
8. Assumed concrete backfill minimum $f_c = 2500$ psi (17.2 MPa).
9. Rebar ties shall be placed over the 18 mm dia. steel hooks cast in the back of the Rosetta® Hardscapes blocks. Assumed ties = 18 in (45.7 cm) long #4 rebar bent into U-Shaped ties (each leg = 9 in. (22.9cm)).

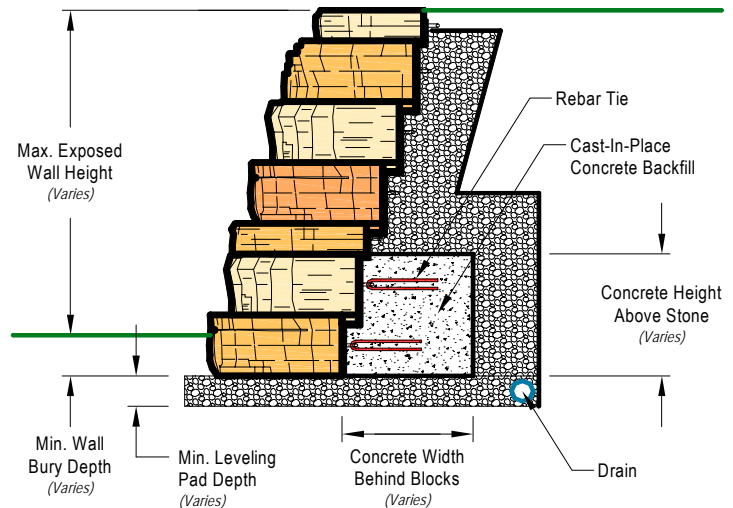



See Project Specific Design Drawings for Full Construction Details

April 29, 2008

ROSETTA® HARDSCAPES LLC - PRELIMINARY WALL HEIGHT GUIDE

GRAVITY WALL WITH POURED-IN-PLACE CONCRETE BACKFILL

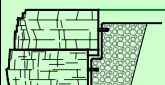
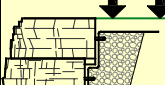
Silty Sand, Fine to Medium Sand with an Internal Angle of Friction (ϕ) = 30°

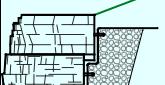
Wall Loading Condition	Design Height		Minimum Wall Bury Depth		Minimum Leveling Pad Depth		Concrete Width Behind Blocks		Concrete Height Above Stone		Maximum Exposed Wall Height	
	ft	(m)	ft	(m)	ft	(m)	ft	(m)	ft	(m)	ft	(m)
<ul style="list-style-type: none"> • NO BACKSLOPE • NO SURCHARGE  <p>$\phi = 30^\circ$</p>	≤ 6.0 (1.83)		See Preliminary Gravity Charts									
	7.0	(2.13)	0.5	(0.15)	0.5	(0.15)	1.5	(0.46)	1.0	(0.30)	6.5	(1.98)
	8.0	(2.44)	0.5	(0.15)	0.5	(0.15)	2.0	(0.61)	2.0	(0.61)	7.5	(2.29)
	9.0	(2.74)	0.5	(0.15)	0.5	(0.15)	2.5	(0.76)	3.0	(0.91)	8.5	(2.59)
<ul style="list-style-type: none"> • NO BACKSLOPE • 100 psf (4.79 kPa) LIVE LOAD SURCHARGE  <p>$\phi = 30^\circ$</p>	≤ 4.5 (1.37)		See Preliminary Gravity Charts									
	5.0	(1.52)	0.5	(0.15)	0.5	(0.15)	1.0	(0.30)	1.0	(0.30)	4.5	(1.37)
	6.0	(1.83)	0.5	(0.15)	0.5	(0.15)	1.5	(0.46)	2.0	(0.61)	5.5	(1.68)
	7.0	(2.13)	0.5	(0.15)	0.5	(0.15)	2.0	(0.61)	3.0	(0.91)	6.5	(1.98)
<ul style="list-style-type: none"> • NO BACKSLOPE • 250 psf (11.96 kPa) LIVE LOAD SURCHARGE  <p>$\phi = 30^\circ$</p>	4.0	(1.22)	0.5	(0.15)	0.5	(0.15)	1.5	(0.46)	1.0	(0.30)	3.5	(1.07)
	5.0	(1.52)	0.5	(0.15)	0.5	(0.15)	2.0	(0.61)	2.0	(0.61)	4.5	(1.37)
	6.0	(1.83)	0.5	(0.15)	0.5	(0.15)	2.5	(0.76)	3.0	(0.91)	5.5	(1.68)
<ul style="list-style-type: none"> • 1:2.5 (21.8°) BACKSLOPE • NO SURCHARGE  <p>$\phi = 30^\circ$</p>	≤ 4.5 (1.37)		See Preliminary Gravity Charts									
	5.0	(1.52)	0.5	(0.15)	0.5	(0.15)	1.5	(0.46)	1.0	(0.30)	4.5	(1.37)
	6.0	(1.83)	0.5	(0.15)	0.5	(0.15)	2.0	(0.61)	2.0	(0.61)	5.5	(1.68)
	7.0	(2.13)	0.5	(0.15)	0.5	(0.15)	2.5	(0.76)	3.0	(0.91)	6.5	(1.98)

NOTES: The above chart was prepared by Rosetta® Hardscapes LLC for estimating and conceptual design purposes only. All information is believed to be true and accurate, however, Rosetta® Hardscapes LLC assumes no responsibility for the use of these design charts for actual construction. Determination of the suitability of each chart is the sole responsibility of the user. Final designs for construction purposes must be performed by a registered Professional Engineer using the actual conditions of the proposed site.

1. Unit weight of 28°, 30°, 34° and 40° soils is assumed to be 120pcf (18.9 kN/m³).
2. Minimum factors of safety are 1.5 for sliding, 1.5 for overturning and 2.0 for bearing capacity.
3. Global stability has not been addressed in these charts.
4. The wall design shall address both internal and external drainage and shall be evaluated by the Professional Engineer who is responsible for the final wall design.
5. Backfill material to be compacted to 95% standard proctor.
6. All Rosetta® Hardscapes LLC Wall System Specifications are to be followed.
7. Block sizes and placement shown for reference only. Individual Rosetta® Hardscapes blocks will vary with installation pattern.
8. Assumed concrete backfill minimum $f_c = 2500$ psi (17.2 MPa).
9. Rebar ties shall be placed over the 18 mm dia. steel hooks cast in the back of the Rosetta® Hardscapes blocks. Assumed ties = 18 in (45.7 cm) long #4 rebar bent into U-Shaped ties (each leg = 9 in. (22.9cm)).

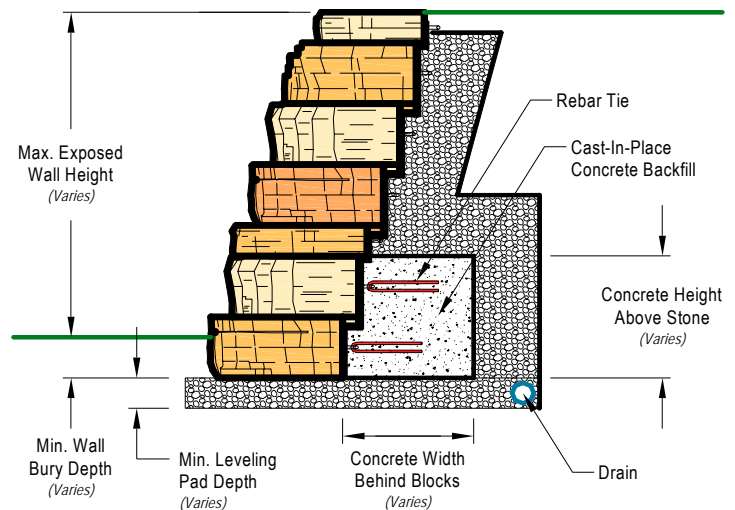

See Project Specific Design Drawings for Full Construction Details

April 29, 2008

ROSETTA® HARDSCAPES LLC - PRELIMINARY WALL HEIGHT GUIDE

GRAVITY WALL WITH POURED-IN-PLACE CONCRETE BACKFILL

Silty Sand, Clayey Sand with an Internal Angle of Friction (ϕ) = 28°

Wall Loading Condition	Design Height ft (m)	Minimum Wall Bury Depth ft (m)	Minimum Leveling Pad Depth ft (m)	Concrete Width Behind Blocks ft (m)	Concrete Height Above Stone ft (m)	Maximum Exposed Wall Height ft (m)
<ul style="list-style-type: none"> • NO BACKSLOPE • NO SURCHARGE <p>$\phi = 28^\circ$</p>	≤ 5.5 (1.68)	See Preliminary Gravity Charts				
	6.0 (1.83)	0.5 (0.15)	0.5 (0.15)	1.5 (0.46)	1.0 (0.30)	5.5 (1.68)
	7.0 (2.13)	0.5 (0.15)	0.5 (0.15)	2.0 (0.61)	2.0 (0.61)	6.5 (1.98)
	8.0 (2.44)	0.5 (0.15)	0.5 (0.15)	2.5 (0.76)	3.0 (0.91)	7.5 (2.29)
<ul style="list-style-type: none"> • NO BACKSLOPE • 100 psf (4.79 kPa) LIVE LOAD SURCHARGE <p>$\phi = 28^\circ$</p>	≤ 4.0 (1.22)	See Preliminary Gravity Charts				
	5.0 (1.52)	0.5 (0.15)	0.5 (0.15)	1.5 (0.46)	1.0 (0.30)	4.5 (1.37)
	6.0 (1.83)	0.5 (0.15)	0.5 (0.15)	2.0 (0.61)	2.0 (0.61)	5.5 (1.68)
	7.0 (2.13)	0.5 (0.15)	0.5 (0.15)	2.5 (0.76)	3.0 (0.91)	6.5 (1.98)
<ul style="list-style-type: none"> • NO BACKSLOPE • 250 psf (11.96 kPa) LIVE LOAD SURCHARGE <p>$\phi = 28^\circ$</p>	4.0 (1.22)	0.5 (0.15)	0.5 (0.15)	2.0 (0.61)	1.0 (0.30)	3.5 (1.07)
	5.0 (1.52)	0.5 (0.15)	0.5 (0.15)	2.5 (0.76)	2.0 (0.61)	4.5 (1.37)
	6.0 (1.83)	0.5 (0.15)	0.5 (0.15)	3.0 (0.91)	3.0 (0.91)	5.5 (1.68)
<ul style="list-style-type: none"> • 1:2.5 (21.8°) BACKSLOPE • NO SURCHARGE <p>$\phi = 28^\circ$</p>	≤ 4.0 (1.22)	See Preliminary Gravity Charts				
	5.0 (1.52)	0.5 (0.15)	0.5 (0.15)	2.5 (0.76)	1.0 (0.30)	4.5 (1.37)
	6.0 (1.83)	0.5 (0.15)	0.5 (0.15)	3.0 (0.91)	2.0 (0.61)	5.5 (1.68)
	7.0 (2.13)	0.5 (0.15)	0.5 (0.15)	4.0 (1.22)	3.0 (0.91)	6.5 (1.98)

NOTES: The above chart was prepared by Rosetta® Hardscapes LLC for estimating and conceptual design purposes only. All information is believed to be true and accurate, however, Rosetta® Hardscapes LLC assumes no responsibility for the use of these design charts for actual construction. Determination of the suitability of each chart is the sole responsibility of the user. Final designs for construction purposes must be performed by a registered Professional Engineer using the actual conditions of the proposed site.

1. Unit weight of 28°, 30°, 34° and 40° soils is assumed to be 120pcf (18.9 kN/m³).
2. Minimum factors of safety are 1.5 for sliding, 1.5 for overturning and 2.0 for bearing capacity.
3. Global stability has not been addressed in these charts.
4. The wall design shall address both internal and external drainage and shall be evaluated by the Professional Engineer who is responsible for the final wall design.
5. Backfill material to be compacted to 95% standard proctor.
6. All Rosetta® Hardscapes LLC Wall System Specifications are to be followed.
7. Block sizes and placement shown for reference only. Individual Rosetta® Hardscapes blocks will vary with installation pattern.
8. Assumed concrete backfill minimum $f_c = 2500$ psi (17.2 MPa).
9. Rebar ties shall be placed over the 18 mm dia. steel hooks cast in the back of the Rosetta® Hardscapes blocks. Assumed ties = 18 in (45.7 cm) long #4 rebar bent into U-Shaped ties (each leg = 9 in. (22.9cm)).

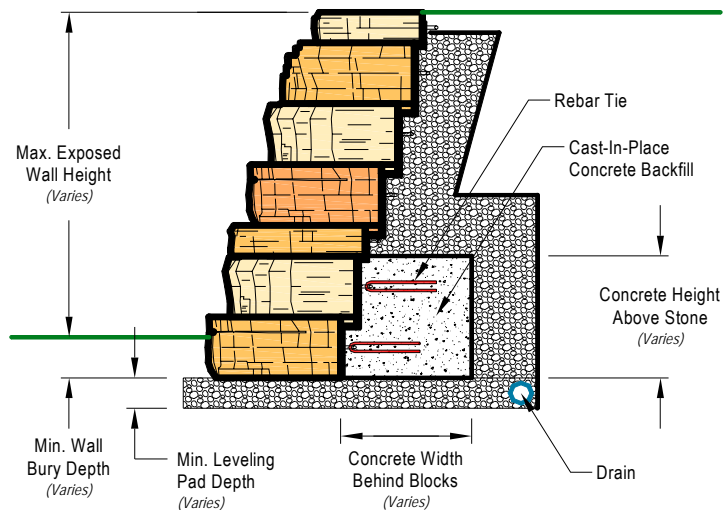

See Project Specific Design Drawings for Full Construction Details

April 29, 2008

REINFORCED

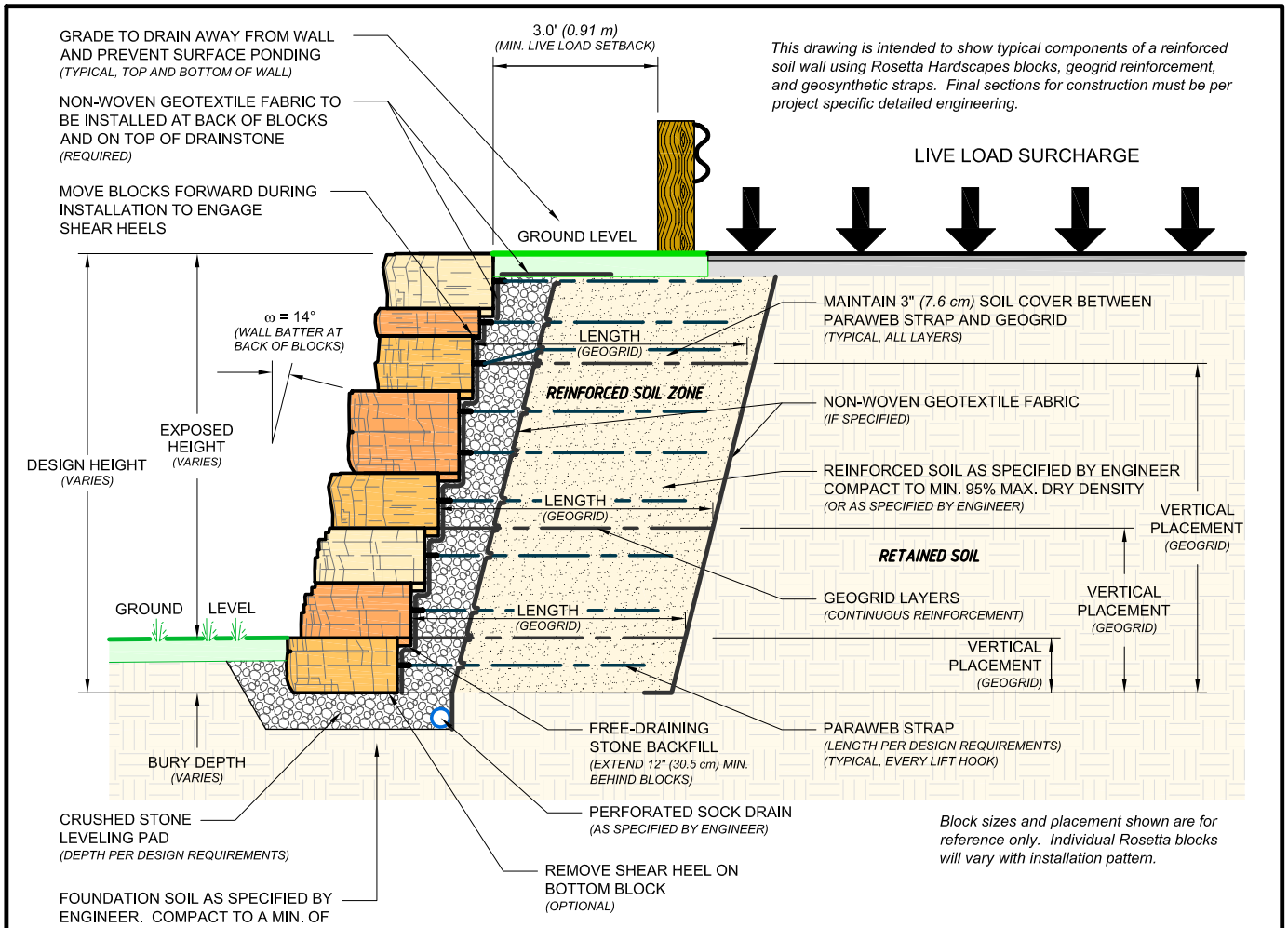

This drawing is intended to show typical components of a reinforced soil wall using Rosetta Hardscapes blocks, geogrid reinforcement, and geosynthetic straps. Final sections for construction must be per project specific detailed engineering.

TYPICAL REINFORCED WALL SECTION

(NO SCALE)

Block sizes and placement shown are for reference only. Individual Rosetta blocks will vary with installation pattern.

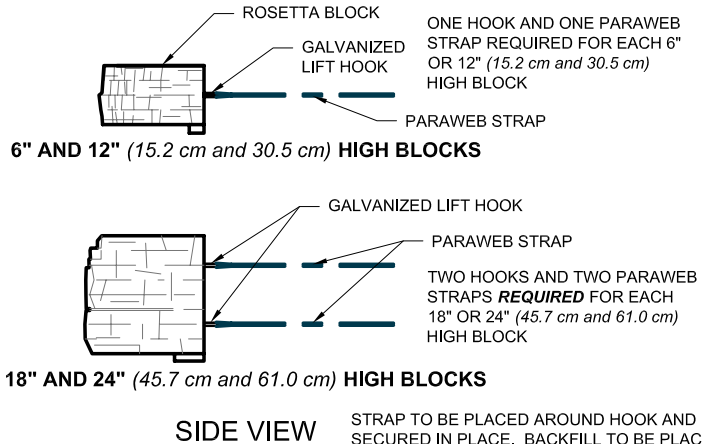
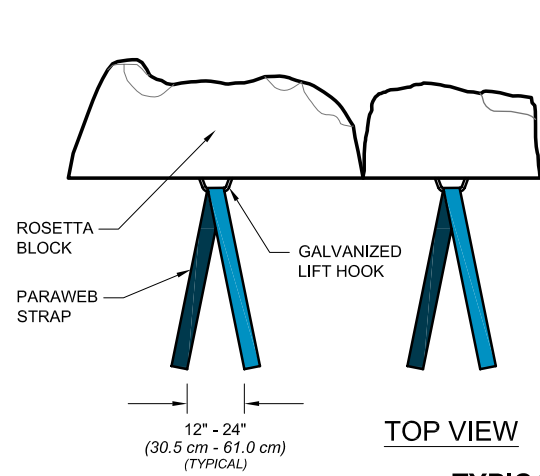

TYPICAL STRAP CONNECTION

(NO SCALE)

STRAP TO BE PLACED AROUND HOOK AND SECURED IN PLACE. BACKFILL TO BE PLACED AND COMPACTED FROM THE ROSETTA BLOCK BACK INTO THE REINFORCED SOIL ZONE TO AVOID "BUNCHING" OF THE STRAP.

DRAWN BY: J. Johnson	TITLE: TYPICAL COMPONENTS OF A REINFORCED WALL SECTION
APPROVED BY:	
DATE: February 28, 2008	DRAWING FILE: Reinforced Wall - Typical Section.dwg

TYPICAL COMPONENTS OF A REINFORCED WALL SECTION	
Reinforced Wall - Typical Section.dwg	

ROSETTA
HARDSCAPES, LLC

05481 US 31 SOUTH CHARLEVOIX, MI 49720
877-777-6558 • 231-237-9656 Fax • www.discoverrosetta.com

ROSETTA® HARDSCAPES LLC - PRELIMINARY WALL HEIGHT GUIDE

**Dense Well-Graded Sand, Sand and Gravel
with an Internal Angle of Friction (ϕ) = 34°**

- Soil Reinforced with Mirafi Miragrid
- Facing Blocks Connected to Reinforced Soil Mass with Paraweb Geosynthetic Strap
- No Surcharge, No Back Slope, No Front Slope



Wall Height ft (m)	Wall Bury Depth ft (m)	Leveling Pad Depth ft (m)	Paraweb 30 Strap Length/Hook ft (m)	GEOGRID LAYOUT						Approx. Geogrid syd/LF wall (sq m/m wall)	Approx. Paraweb ft/LF wall (m/m wall)	
				Grid Type Specified for Each Layer								
				Vertical Placement (V.P.) of Geogrid Layers Measured Up From Top of Leveling Pad						ft (m)	ft (m)	
				Geogrid Length Measured from the Back of the Blocks						ft (m)	ft (m)	
0 - 6.0 (0 - 1.83)	See Gravity Charts											
7.0 (2.13)	0.5 (0.15)	0.5 (0.15)	9.0 (2.74)	Type V.P. Length	2XT 1.0 (0.30) 3.0 (0.91)	2XT 3.0 (0.91) 3.0 (0.91)	2XT 5.0 (1.52) 4.0 (1.22)				1.1 (3.05)	18.3 (18.27)
8.0 (2.44)	0.5 (0.15)	0.5 (0.15)	9.0 (2.74)	Type V.P. Length	2XT 1.0 (0.30) 3.5 (1.07)	2XT 3.5 (1.07) 3.5 (1.07)	2XT 6.0 (1.83) 4.5 (1.37)				1.3 (3.51)	20.9 (20.88)
9.0 (2.74)	0.5 (0.15)	0.5 (0.15)	9.0 (2.74)	Type V.P. Length	2XT 1.0 (0.30) 4.0 (1.22)	2XT 3.0 (0.91) 4.0 (1.22)	2XT 5.0 (1.52) 4.0 (1.22)	2XT 7.0 (2.13) 5.0 (1.52)			1.9 (5.18)	23.5 (23.49)
10.0 (3.05)	0.5 (0.15)	0.5 (0.15)	9.0 (2.74)	Type V.P. Length	3XT 1.0 (0.30) 5.0 (1.52)	3XT 3.0 (0.91) 5.0 (1.52)	3XT 5.5 (1.68) 5.0 (1.52)	3XT 8.0 (2.44) 5.5 (1.68)			2.3 (6.25)	26.1 (26.10)
11.0 (3.35)	0.67 (0.20)	0.5 (0.15)	9.0 (2.74)	Type V.P. Length	3XT 1.5 (0.46) 5.5 (1.68)	3XT 4.0 (1.22) 5.5 (1.68)	3XT 6.5 (1.98) 5.5 (1.68)	3XT 9.0 (2.74) 6.0 (1.83)			2.5 (6.86)	28.7 (28.71)
12.0 (3.66)	0.67 (0.20)	0.5 (0.15)	9.0 (2.74)	Type V.P. Length	3XT 1.0 (0.30) 6.0 (1.83)	3XT 3.0 (0.91) 6.0 (1.83)	3XT 5.0 (1.52) 6.0 (1.83)	3XT 7.5 (2.29) 6.0 (1.83)	3XT 10.0 (3.05) 6.5 (1.98)		3.4 (9.30)	31.3 (31.32)
13.0 (3.96)	0.75 (0.23)	0.5 (0.15)	9.0 (2.74)	Type V.P. Length	3XT 1.0 (0.30) 6.5 (1.98)	3XT 3.0 (0.91) 6.5 (1.98)	3XT 5.5 (1.68) 6.5 (1.98)	3XT 8.0 (2.44) 6.5 (1.98)	3XT 10.5 (3.20) 6.5 (1.98)		3.6 (9.91)	33.9 (33.93)
14.0 (4.27)	0.75 (0.23)	0.5 (0.15)	9.0 (2.74)	Type V.P. Length	3XT 1.0 (0.30) 7.0 (2.13)	3XT 3.0 (0.91) 7.0 (2.13)	3XT 5.0 (1.52) 7.0 (2.13)	3XT 7.0 (2.13) 7.0 (2.13)	3XT 9.5 (2.90) 7.0 (2.13)	3XT 12.0 (3.66) 7.5 (2.29)	4.7 (12.95)	36.5 (36.54)
15.0 (4.57)	0.75 (0.23)	0.5 (0.15)	9.0 (2.74)	Type V.P. Length	3XT 1.0 (0.30) 8.0 (2.44)	3XT 3.5 (1.07) 8.0 (2.44)	3XT 6.0 (1.83) 8.0 (2.44)	3XT 8.5 (2.59) 8.0 (2.44)	3XT 11.0 (3.35) 8.0 (2.44)	3XT 13.5 (4.11) 8.0 (2.44)	5.3 (14.63)	39.2 (39.15)
Wall heights greater than 15.0' (4.57 m) are achievable.												

NOTES: The above chart was prepared by Rosetta® Hardscapes LLC for estimating and conceptual design purposes only. All information is believed to be true and accurate, however, Rosetta® Hardscapes LLC assumes no responsibility for the use of these design charts for actual construction. Determination of the suitability of each chart is the sole responsibility of the user. **Final designs for construction purposes must be performed by a registered Professional Engineer** using the actual conditions of the proposed site.

1. Unit weight of 28°, 30°, 34° and 40° soils is assumed to be 120pcf (18.9 kN/m3).
2. Minimum factors of safety are 1.5 for sliding, 2.0 for overturning and 2.0 for bearing capacity.
3. Designs are in general accordance with NCMA's *Design Manual for Segmental Retaining Walls (2nd ed.)*.
4. Global stability has not been addressed in these charts.
5. The wall design shall address both internal and external drainage and shall be evaluated by the Professional Engineer who is responsible for the final wall design.
6. Backfill material to be compacted to 95% standard proctor.
7. All Rosetta® Hardscapes LLC Wall System Specifications are to be followed.
8. Each Rosetta® block must be connected into the reinforced soil mass with individual Paraweb® geosynthetic straps. The straps are to be wrapped around the galvanized lift hook on the back of the block.
9. The 6" and 12" high Rosetta® blocks have one galvanized lift hook and require one strap per block. The 18" high and 24" high Rosetta® blocks have two galvanized lift hooks and require two straps per block.
10. Paraweb strap length in chart is total length. Since the strap is looped around the lift hook, the strap extends half the total distance behind the blocks.

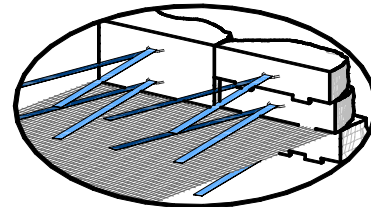

SCHEMATIC STRAP/GRID LAYOUT

- Geogrid Placed Flush to Back of Blocks
- Strap Wrapped Around Lift Hook on Block
- Maintain 3" of Compacted Soil Between Geogrid and Strap (Typ., All Levels)
- Geotextile Fabric and Stone Required Behind Blocks (Not Shown For Clarity)

February 26, 2008

ROSETTA® HARDSCAPES LLC - PRELIMINARY WALL HEIGHT GUIDE

**Dense Well-Graded Sand, Sand and Gravel
with an Internal Angle of Friction (ϕ) = 34°**

- Soil Reinforced with Mirafli Miragrid
- Facing Blocks Connected to Reinforced Soil Mass with Paraweb Geosynthetic Strap
- 100 psf (4.79 kPa) Live Load Surcharge, No Back Slope, No Front Slope

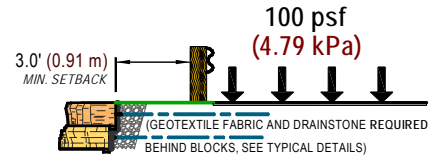

Wall Height ft (m)	Wall Bury Depth ft (m)	Leveling Pad Depth ft (m)	Paraweb 30 Strap Length/Hook ft (m)	GEOGRID LAYOUT						Approx. Geogrid syd/LF wall (sq m/m wall)	Approx. Paraweb ft/LF wall (m/m wall)	
				Grid Type Specified for Each Layer								
				Vertical Placement (V.P.) of Geogrid Layers Measured Up From Top of Leveling Pad								
				Geogrid Length Measured from the Back of the Blocks								
0 - 5.0 (0 - 1.52)	See Gravity Charts											
6.0 (1.83)	0.5 (0.15)	0.5 (0.15)	11.0 (3.35)	Type V.P. Length	2XT 1.5 (0.46) 3.0 (0.91)	2XT 4.0 (1.22) 3.5 (1.07)					0.7 (1.98)	19.1 (19.14)
7.0 (2.13)	0.5 (0.15)	0.5 (0.15)	11.0 (3.35)	Type V.P. Length	2XT 1.0 (0.30) 3.0 (0.91)	2XT 3.0 (0.91) 3.0 (0.91)	2XT 5.0 (1.52) 4.0 (1.22)				1.1 (3.05)	22.3 (22.33)
8.0 (2.44)	0.5 (0.15)	0.5 (0.15)	11.0 (3.35)	Type V.P. Length	2XT 1.0 (0.30) 3.5 (1.07)	2XT 3.5 (1.07) 3.5 (1.07)	2XT 6.0 (1.83) 4.5 (1.37)				1.3 (3.51)	25.5 (25.52)
9.0 (2.74)	0.5 (0.15)	0.5 (0.15)	11.0 (3.35)	Type V.P. Length	2XT 1.0 (0.30) 4.0 (1.22)	2XT 3.0 (0.91) 4.0 (1.22)	2XT 5.0 (1.52) 4.0 (1.22)	2XT 7.0 (2.13) 5.0 (1.52)			1.9 (5.18)	28.7 (28.71)
10.0 (3.05)	0.5 (0.15)	0.5 (0.15)	11.0 (3.35)	Type V.P. Length	3XT 1.0 (0.30) 5.0 (1.52)	3XT 3.0 (0.91) 5.0 (1.52)	3XT 5.5 (1.68) 5.0 (1.52)	3XT 8.0 (2.44) 5.5 (1.68)			2.3 (6.25)	31.9 (31.90)
11.0 (3.35)	0.67 (0.20)	0.5 (0.15)	11.0 (3.35)	Type V.P. Length	3XT 1.5 (0.46) 5.5 (1.68)	3XT 4.0 (1.22) 5.5 (1.68)	3XT 6.5 (1.98) 5.5 (1.68)	3XT 9.0 (2.74) 6.0 (1.83)			2.5 (6.86)	35.1 (35.09)
12.0 (3.66)	0.67 (0.20)	0.5 (0.15)	11.0 (3.35)	Type V.P. Length	3XT 1.0 (0.30) 6.0 (1.83)	3XT 3.0 (0.91) 6.0 (1.83)	3XT 5.0 (1.52) 6.0 (1.83)	3XT 7.5 (2.29) 6.0 (1.83)	3XT 10.0 (3.05) 6.5 (1.98)		3.4 (9.30)	38.3 (38.28)
13.0 (3.96)	0.75 (0.23)	0.5 (0.15)	11.0 (3.35)	Type V.P. Length	3XT 1.0 (0.30) 6.5 (1.98)	3XT 3.0 (0.91) 6.5 (1.98)	3XT 5.0 (1.52) 6.5 (1.98)	3XT 7.0 (2.13) 6.5 (1.98)	3XT 9.0 (2.74) 6.5 (1.98)	3XT 11.0 (3.35) 7.0 (2.13)	4.4 (12.04)	41.5 (41.47)
14.0 (4.27)	0.75 (0.23)	0.5 (0.15)	11.0 (3.35)	Type V.P. Length	3XT 1.0 (0.30) 7.0 (2.13)	3XT 3.0 (0.91) 7.0 (2.13)	3XT 5.0 (1.52) 7.0 (2.13)	3XT 7.0 (2.13) 7.0 (2.13)	3XT 9.5 (2.90) 7.0 (2.13)	3XT 12.0 (3.66) 7.5 (2.29)	4.7 (12.95)	44.7 (44.66)
15.0 (4.57)	0.75 (0.23)	0.5 (0.15)	11.0 (3.35)	Type V.P. Length	3XT 1.0 (0.30) 8.0 (2.44)	3XT 3.0 (0.91) 8.0 (2.44)	3XT 5.5 (1.68) 8.0 (2.44)	3XT 8.0 (2.44) 8.0 (2.44)	3XT 10.5 (3.20) 8.0 (2.44)	3XT 13.0 (3.96) 8.0 (2.44)	5.3 (14.63)	47.9 (47.85)
Wall heights greater than 15.0' (4.57 m) are achievable.												

- NOTES:** The above chart was prepared by Rosetta® Hardscapes LLC for estimating and conceptual design purposes only. All information is believed to be true and accurate, however, Rosetta® Hardscapes LLC assumes no responsibility for the use of these design charts for actual construction. Determination of the suitability of each chart is the sole responsibility of the user. **Final designs for construction purposes must be performed by a registered Professional Engineer** using the actual conditions of the proposed site.
1. Unit weight of 28°, 30°, 34° and 40° soils is assumed to be 120pcf (18.9 kN/m³).
 2. Minimum factors of safety are 1.5 for sliding, 2.0 for overturning and 2.0 for bearing capacity.
 3. Designs are in general accordance with NCMA's *Design Manual for Segmental Retaining Walls (2nd ed.)*.
 4. Global stability has not been addressed in these charts.
 5. The wall design shall address both internal and external drainage and shall be evaluated by the Professional Engineer who is responsible for the final wall design.
 6. Backfill material to be compacted to 95% standard proctor.
 7. All Rosetta® Hardscapes LLC Wall System Specifications are to be followed.
 8. Each Rosetta® block must be connected into the reinforced soil mass with individual Paraweb® geosynthetic straps. The straps are to be wrapped around the galvanized lift hook on the back of the block.
 9. The 6" and 12" high Rosetta® blocks have one galvanized lift hook and require one strap per block. The 18" high and 24" high Rosetta® blocks have two galvanized lift hooks and require two straps per block.
 10. Paraweb strap length in chart is total length. Since the strap is looped around the lift hook, the strap extends half the total distance behind the blocks.

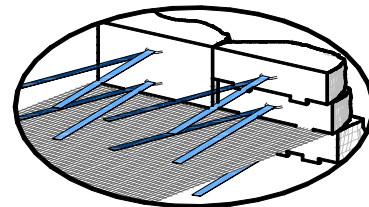

- SCHEMATIC STRAP/GRID LAYOUT**
- Geogrid Placed Flush to Back of Blocks
 - Strap Wrapped Around Lift Hook on Block
 - Maintain 3" of Compacted Soil Between Geogrid and Strap (Typ., All Levels)
 - Geotextile Fabric and Stone Required Behind Blocks (Not Shown For Clarity)

February 26, 2008

ROSETTA® HARDSCAPES LLC - PRELIMINARY WALL HEIGHT GUIDE

**Dense Well-Graded Sand, Sand and Gravel
with an Internal Angle of Friction (ϕ) = 34°**

- Soil Reinforced with Mirafi Miragrid
- Facing Blocks Connected to Reinforced Soil Mass with Paraweb Geosynthetic Strap
- 250 psf (11.96 kPa) Live Load Surcharge, No Back Slope, No Front Slope

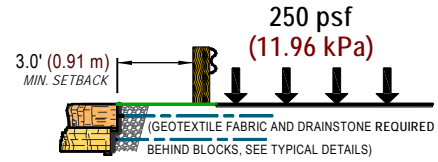

Wall Height ft (m)	Wall Bury Depth ft (m)	Leveling Pad Depth ft (m)	Paraweb 30 Strap Length/Hook ft (m)	GEOGRID LAYOUT						Approx. Geogrid syd/LF wall (sq m/m wall)	Approx. Paraweb ft/LF wall (m/m wall)	
				Grid Type Specified for Each Layer								
				Vertical Placement (V.P.) of Geogrid Layers Measured Up From Top of Leveling Pad						ft (m)		
				Geogrid Length Measured from the Back of the Blocks						ft (m)		
0 - 3.0 (0 - 0.91)	Analyze As Gravity Wall											
4.0 (1.22)	0.5 (0.15)	0.5 (0.15)	13.0 (3.96)	Type V. P. Length	2XT 1.0 (0.30) 3.0 (0.91)	2XT 3.0 (0.91) 3.0 (0.91)					0.7 (1.83)	15.1 (15.08)
5.0 (1.52)	0.5 (0.15)	0.5 (0.15)	13.0 (3.96)	Type V. P. Length	2XT 1.0 (0.30) 3.0 (0.91)	2XT 3.5 (1.07) 3.5 (1.07)					0.7 (1.98)	18.9 (18.85)
6.0 (1.83)	0.5 (0.15)	0.5 (0.15)	13.0 (3.96)	Type V. P. Length	2XT 1.5 (0.46) 3.0 (0.91)	2XT 4.0 (1.22) 3.5 (1.07)					0.7 (1.98)	22.6 (22.62)
7.0 (2.13)	0.5 (0.15)	0.5 (0.15)	13.0 (3.96)	Type V. P. Length	2XT 1.0 (0.30) 3.0 (0.91)	2XT 3.0 (0.91) 3.0 (0.91)	2XT 5.0 (1.52) 4.0 (1.22)				1.1 (3.05)	26.4 (26.39)
8.0 (2.44)	0.5 (0.15)	0.5 (0.15)	13.0 (3.96)	Type V. P. Length	2XT 1.0 (0.30) 3.5 (1.07)	2XT 3.5 (1.07) 3.5 (1.07)	2XT 6.0 (1.83) 4.5 (1.37)				1.3 (3.51)	30.2 (30.16)
9.0 (2.74)	0.5 (0.15)	0.5 (0.15)	13.0 (3.96)	Type V. P. Length	2XT 1.0 (0.30) 4.0 (1.22)	2XT 3.0 (0.91) 4.0 (1.22)	2XT 5.0 (1.52) 4.0 (1.22)	2XT 7.0 (2.13) 5.0 (1.52)			1.9 (5.18)	33.9 (33.93)
10.0 (3.05)	0.5 (0.15)	0.5 (0.15)	13.0 (3.96)	Type V. P. Length	3XT 1.0 (0.30) 5.0 (1.52)	3XT 3.0 (0.91) 5.0 (1.52)	3XT 5.5 (1.68) 5.0 (1.52)	3XT 8.0 (2.44) 5.5 (1.68)			2.3 (6.25)	37.7 (37.70)
11.0 (3.35)	0.67 (0.20)	0.5 (0.15)	13.0 (3.96)	Type V. P. Length	3XT 1.5 (0.46) 5.5 (1.68)	3XT 4.0 (1.22) 5.5 (1.68)	3XT 6.5 (1.98) 5.5 (1.68)	3XT 9.0 (2.74) 6.0 (1.83)			2.5 (6.86)	41.5 (41.47)
12.0 (3.66)	0.67 (0.20)	0.5 (0.15)	13.0 (3.96)	Type V. P. Length	3XT 1.0 (0.30) 6.0 (1.83)	3XT 3.0 (0.91) 6.0 (1.83)	3XT 5.0 (1.52) 6.0 (1.83)	3XT 7.5 (2.29) 6.0 (1.83)	3XT 10.0 (3.05) 6.5 (1.98)		3.4 (9.30)	45.2 (45.24)
13.0 (3.96)	0.75 (0.23)	0.5 (0.15)	13.0 (3.96)	Type V. P. Length	3XT 1.0 (0.30) 7.0 (2.13)	3XT 3.0 (0.91) 7.0 (2.13)	3XT 5.0 (1.52) 7.0 (2.13)	3XT 7.0 (2.13) 7.0 (2.13)	3XT 9.0 (2.74) 7.0 (2.13)	3XT 11.0 (3.35) 7.0 (2.13)	4.7 (12.80)	49.0 (49.01)
14.0 (4.27)	0.75 (0.23)	0.5 (0.15)	13.0 (3.96)	Type V. P. Length	3XT 1.0 (0.30) 7.0 (2.13)	3XT 3.0 (0.91) 7.0 (2.13)	3XT 5.0 (1.52) 7.0 (2.13)	3XT 7.0 (2.13) 7.0 (2.13)	3XT 9.5 (2.90) 7.0 (2.13)	3XT 12.0 (3.66) 7.5 (2.29)	4.7 (12.95)	52.8 (52.78)
15.0 (4.57)	0.75 (0.23)	0.5 (0.15)	13.0 (3.96)	Type V. P. Length	3XT 1.0 (0.30) 8.0 (2.44)	3XT 3.0 (0.91) 8.0 (2.44)	3XT 5.5 (1.68) 8.0 (2.44)	3XT 8.0 (2.44) 8.0 (2.44)	3XT 10.5 (3.20) 8.0 (2.44)	3XT 13.0 (3.96) 8.0 (2.44)	5.3 (14.63)	56.6 (56.55)
Wall heights greater than 15.0' (4.57 m) are achievable.												

- NOTES:** The above chart was prepared by Rosetta® Hardscapes LLC for estimating and conceptual design purposes only. All information is believed to be true and accurate, however, Rosetta® Hardscapes LLC assumes no responsibility for the use of these design charts for actual construction. Determination of the suitability of each chart is the sole responsibility of the user. Final designs for construction purposes must be performed by a registered Professional Engineer using the actual conditions of the proposed site.
1. Unit weight of 28°, 30°, 34° and 40° soils is assumed to be 120pcf (18.9 kN/m³).
 2. Minimum factors of safety are 1.5 for sliding, 2.0 for overturning and 2.0 for bearing capacity.
 3. Designs are in general accordance with NCMA's *Design Manual for Segmental Retaining Walls (2nd ed.)*.
 4. Global stability has not been addressed in these charts.
 5. The wall design shall address both internal and external drainage and shall be evaluated by the Professional Engineer who is responsible for the final wall design.
 6. Backfill material to be compacted to 95% standard proctor.
 7. All Rosetta® Hardscapes LLC Wall System Specifications are to be followed.
 8. Each Rosetta® block must be connected into the reinforced soil mass with individual Paraweb® geosynthetic straps. The straps are to be wrapped around the galvanized lift hook on the back of the block.
 9. The 6" and 12" high Rosetta® blocks have one galvanized lift hook and require one strap per block. The 18" high and 24" high Rosetta® blocks have two galvanized lift hooks and require two straps per block.
 10. Paraweb strap length in chart is total length. Since the strap is looped around the lift hook, the strap extends half the total distance behind the blocks.

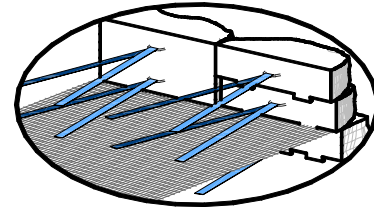

- SCHEMATIC STRAP/GRID LAYOUT**
- Geogrid Placed Flush to Back of Blocks
 - Strap Wrapped Around Lift Hook on Block
 - Maintain 3" of Compacted Soil Between Geogrid and Strap (Typ., All Levels)
 - Geotextile Fabric and Stone Required Behind Blocks (Not Shown For Clarity)

February 26, 2008

ROSETTA® HARDSCAPES LLC - PRELIMINARY WALL HEIGHT GUIDE

Dense Well-Graded Sand, Sand and Gravel
with an Internal Angle of Friction (ϕ) = 34°

- Soil Reinforced with Mirafi Miragrid
- Facing Blocks Connected to Reinforced Soil Mass with Paraweb Geosynthetic Strap
- 1:2.5 (21.8°) Back Slope, No Surcharge, No Front Slope

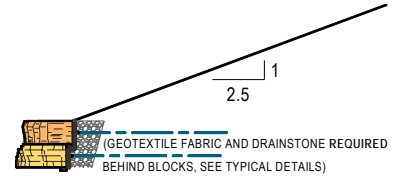

Wall Height ft (m)	Wall Bury Depth ft (m)	Leveling Pad Depth ft (m)	Paraweb 30 Strap Length/Hook ft (m)	GEOGRID LAYOUT <i>Grid Type Specified for Each Layer</i>						Approx. Geogrid syd/LF wall (sq m/m wall)	Approx. Paraweb ft/LF wall (m/m wall)	
				<i>Vertical Placement (V.P.) of Geogrid Layers Measured Up From Top of Leveling Pad</i>						ft (m)	ft (m)	
				<i>Geogrid Length Measured from the Back of the Blocks</i>						ft (m)	ft (m)	
0 - 5.0 (0 - 1.52)	See Gravity Charts											
6.0 (1.83)	0.5 (0.15)	0.5 (0.15)	12.0 (3.66)	Type V. P. Length	2XT 1.5 (0.46) 3.0 (0.91)	2XT 4.0 (1.22) 4.0 (1.22)					0.8 (2.13)	20.9 (20.88)
7.0 (2.13)	0.5 (0.15)	0.5 (0.15)	12.0 (3.66)	Type V. P. Length	2XT 1.0 (0.30) 3.0 (0.91)	2XT 3.5 (1.07) 3.5 (1.07)	2XT 6.0 (1.83) 5.0 (1.52)				1.3 (3.51)	24.4 (24.36)
8.0 (2.44)	0.5 (0.15)	0.5 (0.15)	12.0 (3.66)	Type V. P. Length	2XT 1.0 (0.30) 3.5 (1.07)	2XT 3.5 (1.07) 3.5 (1.07)	2XT 6.0 (1.83) 5.0 (1.52)				1.3 (3.66)	27.8 (27.84)
9.0 (2.74)	0.5 (0.15)	0.5 (0.15)	12.0 (3.66)	Type V. P. Length	2XT 1.0 (0.30) 4.0 (1.22)	2XT 3.0 (0.91) 4.0 (1.22)	2XT 5.5 (1.68) 4.5 (1.37)	2XT 8.0 (2.44) 6.5 (1.98)			2.1 (5.79)	31.3 (31.32)
10.0 (3.05)	0.5 (0.15)	0.5 (0.15)	12.0 (3.66)	Type V. P. Length	3XT 1.0 (0.30) 5.5 (1.68)	3XT 3.5 (1.07) 5.5 (1.68)	3XT 6.0 (1.83) 5.5 (1.68)	3XT 8.5 (2.59) 6.5 (1.98)			2.6 (7.01)	34.8 (34.80)
11.0 (3.35)	0.67 (0.20)	0.5 (0.15)	12.0 (3.66)	Type V. P. Length	3XT 1.5 (0.46) 6.5 (1.98)	3XT 4.0 (1.22) 6.5 (1.98)	3XT 6.5 (1.98) 6.5 (1.98)	3XT 9.0 (2.74) 7.0 (2.13)			2.9 (8.08)	38.3 (38.28)
12.0 (3.66)	0.67 (0.20)	0.5 (0.15)	12.0 (3.66)	Type V. P. Length	3XT 1.0 (0.30) 7.0 (2.13)	3XT 3.5 (1.07) 7.0 (2.13)	3XT 6.0 (1.83) 7.0 (2.13)	3XT 8.5 (2.59) 7.0 (2.13)	3XT 11.0 (3.35) 8.0 (2.44)		4.0 (10.97)	41.8 (41.76)
13.0 (3.96)	0.75 (0.23)	0.5 (0.15)	12.0 (3.66)	Type V. P. Length	3XT 1.0 (0.30) 7.5 (2.29)	3XT 3.0 (0.91) 7.5 (2.29)	3XT 5.0 (1.52) 7.5 (2.29)	3XT 7.0 (2.13) 7.5 (2.29)	3XT 9.0 (2.74) 7.5 (2.29)	3XT 11.0 (3.35) 8.0 (2.44)	5.1 (13.87)	45.2 (45.24)
14.0 (4.27)	0.75 (0.23)	0.5 (0.15)	12.0 (3.66)	Type V. P. Length	3XT 1.0 (0.30) 8.0 (2.44)	3XT 3.0 (0.91) 8.0 (2.44)	3XT 5.5 (1.68) 8.0 (2.44)	3XT 8.0 (2.44) 8.0 (2.44)	3XT 10.5 (3.20) 8.0 (2.44)	3XT 13.0 (3.96) 9.5 (2.90)	5.5 (15.09)	48.7 (48.72)
15.0 (4.57)	0.75 (0.23)	0.5 (0.15)	12.0 (3.66)	Type V. P. Length	3XT 1.0 (0.30) 9.5 (2.90)	3XT 3.0 (0.91) 9.5 (2.90)	3XT 5.5 (1.68) 9.5 (2.90)	3XT 8.0 (2.44) 9.5 (2.90)	3XT 10.5 (3.20) 9.5 (2.90)	3XT 13.0 (3.96) 9.5 (2.90)	6.3 (17.37)	52.2 (52.20)
Wall heights greater than 15.0' (4.57 m) are achievable.												

- NOTES:** The above chart was prepared by Rosetta® Hardscapes LLC for estimating and conceptual design purposes only. All information is believed to be true and accurate, however, Rosetta® Hardscapes LLC assumes no responsibility for the use of these design charts for actual construction. Determination of the suitability of each chart is the sole responsibility of the user. **Final designs for construction purposes must be performed by a registered Professional Engineer** using the actual conditions of the proposed site.
1. Unit weight of 28°, 30°, 34° and 40° soils is assumed to be 120pcf (18.9 kN/m³).
 2. Minimum factors of safety are 1.5 for sliding, 2.0 for overturning and 2.0 for bearing capacity.
 3. Designs are in general accordance with NCMA's *Design Manual for Segmental Retaining Walls (2nd ed.)*.
 4. Global stability has not been addressed in these charts.
 5. The wall design shall address both internal and external drainage and shall be evaluated by the Professional Engineer who is responsible for the final wall design.
 6. Backfill material to be compacted to 95% standard proctor.
 7. All Rosetta® Hardscapes LLC Wall System Specifications are to be followed.
 8. Each Rosetta® block must be connected into the reinforced soil mass with individual Paraweb® geosynthetic straps. The straps are to be wrapped around the galvanized lift hook on the back of the block.
 9. The 6" and 12" high Rosetta® blocks have one galvanized lift hook and require one strap per block. The 18" high and 24" high Rosetta® blocks have two galvanized lift hooks and require two straps per block.
 10. Paraweb strap length in chart is total length. Since the strap is looped around the lift hook, the strap extends half the total distance behind the blocks.

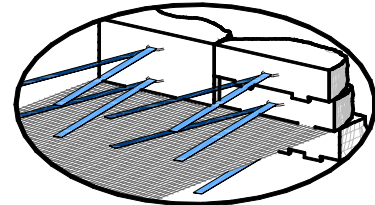

SCHEMATIC STRAP/GRID LAYOUT

- Geogrid Placed Flush to Back of Blocks
- Strap Wrapped Around Lift Hook on Block
- Maintain 3" of Compacted Soil Between Geogrid and Strap (Typ., All Levels)
- Geotextile Fabric and Stone Required Behind Blocks (Not Shown For Clarity)

February 26, 2008

ROSETTA® HARDSCAPES LLC - PRELIMINARY WALL HEIGHT GUIDE

**Silty Sand, Fine to Medium Sand
with an Internal Angle of Friction (ϕ) = 30°**

- Soil Reinforced with Mirafi Miragrid
- Facing Blocks Connected to Reinforced Soil Mass with Paraweb Geosynthetic Strap
- No Surcharge, No Back Slope, No Front Slope



Wall Height ft (m)	Wall Bury Depth ft (m)	Leveling Pad Depth ft (m)	Paraweb 30 Strap Length/Hook ft (m)	GEOGRID LAYOUT								Approx. Geogrid syd/LF wall (sq m/m wall)	Approx. Paraweb ft/LF wall (m/m wall)	
				Grid Type Specified for Each Layer										
				Vertical Placement (V.P.) of Geogrid Layers Measured Up From Top of Leveling Pad										
				Geogrid Length Measured from the Back of the Blocks										
0 - 6.0 (0 - 1.83)	See Gravity Charts													
7.0 (2.13)	0.5 (0.15)	0.5 (0.15)	13.0 (3.96)	Type V. P. Length	2XT 1.0 (0.30) 3.0 (0.91)	2XT 3.0 (0.91) 3.0 (0.91)	2XT 5.0 (1.52) 4.0 (1.22)						1.1 (3.05)	26.4 (26.39)
8.0 (2.44)	0.5 (0.15)	0.5 (0.15)	13.0 (3.96)	Type V. P. Length	2XT 1.0 (0.30) 4.0 (1.22)	2XT 3.5 (1.07) 4.0 (1.22)	2XT 6.0 (1.83) 4.5 (1.37)						1.4 (3.81)	30.2 (30.16)
9.0 (2.74)	0.5 (0.15)	0.5 (0.15)	13.0 (3.96)	Type V. P. Length	2XT 1.0 (0.30) 4.5 (1.37)	2XT 3.0 (0.91) 4.5 (1.37)	2XT 5.0 (1.52) 4.5 (1.37)	2XT 7.0 (2.13) 5.5 (1.68)					2.1 (5.79)	33.9 (33.93)
10.0 (3.05)	0.5 (0.15)	0.5 (0.15)	13.0 (3.96)	Type V. P. Length	3XT 1.0 (0.30) 5.0 (1.52)	3XT 3.0 (0.91) 5.0 (1.52)	3XT 5.5 (1.68) 5.0 (1.52)	3XT 8.0 (2.44) 6.0 (1.83)					2.3 (6.40)	37.7 (37.70)
11.0 (3.35)	0.67 (0.20)	0.5 (0.15)	13.0 (3.96)	Type V. P. Length	3XT 1.5 (0.46) 6.5 (1.98)	3XT 4.0 (1.22) 6.5 (1.98)	3XT 6.5 (1.98) 6.5 (1.98)	3XT 9.0 (2.74) 6.5 (1.98)					2.9 (7.92)	41.5 (41.47)
12.0 (3.66)	0.67 (0.20)	0.5 (0.15)	13.0 (3.96)	Type V. P. Length	3XT 1.0 (0.30) 7.0 (2.13)	3XT 3.0 (0.91) 7.0 (2.13)	3XT 5.0 (1.52) 7.0 (2.13)	3XT 7.5 (2.29) 7.0 (2.13)	3XT 10.0 (3.05) 7.0 (2.13)				3.9 (10.67)	45.2 (45.24)
13.0 (3.96)	0.75 (0.23)	0.5 (0.15)	13.0 (3.96)	Type V. P. Length	3XT 1.0 (0.30) 7.5 (2.29)	3XT 3.0 (0.91) 7.5 (2.29)	3XT 5.5 (1.68) 7.5 (2.29)	3XT 8.0 (2.44) 7.5 (2.29)	3XT 10.5 (3.20) 7.5 (2.29)				4.2 (11.43)	49.0 (49.01)
14.0 (4.27)	0.75 (0.23)	0.5 (0.15)	13.0 (3.96)	Type V. P. Length	3XT 1.0 (0.30) 8.0 (2.44)	3XT 3.0 (0.91) 8.0 (2.44)	3XT 5.0 (1.52) 8.0 (2.44)	3XT 7.0 (2.13) 8.0 (2.44)	3XT 9.5 (2.90) 8.0 (2.44)	3XT 12.0 (3.66) 8.0 (2.44)			5.3 (14.63)	52.8 (52.78)
15.0 (4.57)	0.75 (0.23)	0.5 (0.15)	13.0 (3.96)	Type V. P. Length	3XT 1.0 (0.30) 9.0 (2.74)	3XT 3.5 (1.07) 9.0 (2.74)	3XT 6.0 (1.83) 9.0 (2.74)	3XT 8.5 (2.59) 9.0 (2.74)	3XT 11.0 (3.35) 9.0 (2.74)	3XT 13.5 (4.11) 9.0 (2.74)			6.0 (16.46)	56.6 (56.55)
Wall heights greater than 15.0' (4.57 m) are achievable.														

- NOTES:** The above chart was prepared by Rosetta® Hardscapes LLC for estimating and conceptual design purposes only. All information is believed to be true and accurate, however, Rosetta® Hardscapes LLC assumes no responsibility for the use of these design charts for actual construction. Determination of the suitability of each chart is the sole responsibility of the user. **Final designs for construction purposes must be performed by a registered Professional Engineer** using the actual conditions of the proposed site.
1. Unit weight of 28°, 30°, 34° and 40° soils is assumed to be 120pcf (18.9 kN/m³).
 2. Minimum factors of safety are 1.5 for sliding, 2.0 for overturning and 2.0 for bearing capacity.
 3. Designs are in general accordance with NCMA's *Design Manual for Segmental Retaining Walls (2nd ed.)*.
 4. Global stability has not been addressed in these charts.
 5. The wall design shall address both internal and external drainage and shall be evaluated by the Professional Engineer who is responsible for the final wall design.
 6. Backfill material to be compacted to 95% standard proctor.
 7. All Rosetta® Hardscapes LLC Wall System Specifications are to be followed.
 8. Each Rosetta® block must be connected into the reinforced soil mass with individual Paraweb® geosynthetic straps. The straps are to be wrapped around the galvanized lift hook on the back of the block.
 9. The 6" and 12" high Rosetta® blocks have one galvanized lift hook and require one strap per block. The 18" high and 24" high Rosetta® blocks have two galvanized lift hooks and require two straps per block.
 10. Paraweb strap length in chart is total length. Since the strap is looped around the lift hook, the strap extends half the total distance behind the blocks.

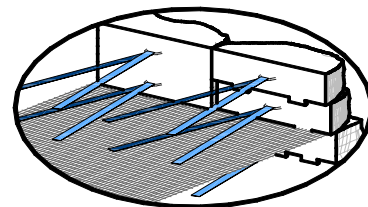

- SCHEMATIC STRAP/GRID LAYOUT**
- Geogrid Placed Flush to Back of Blocks
 - Strap Wrapped Around Lift Hook on Block
 - Maintain 3" of Compacted Soil Between Geogrid and Strap (Typ., All Levels)
 - Geotextile Fabric and Stone Required Behind Blocks (Not Shown For Clarity)

February 26, 2008

ROSETTA® HARDSCAPES LLC - PRELIMINARY WALL HEIGHT GUIDE

**Silty Sand, Fine to Medium Sand
with an Internal Angle of Friction (ϕ) = 30°**

- Soil Reinforced with Mirafi Miragrid
- Facing Blocks Connected to Reinforced Soil Mass with Paraweb Geosynthetic Strap
- 100 psf (4.79 kPa) Live Load Surcharge, No Back Slope, No Front Slope

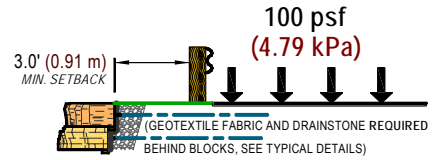

Wall Height ft (m)	Wall Bury Depth ft (m)	Leveling Pad Depth ft (m)	Paraweb 30 Strap Length/Hook ft (m)	GEOGRID LAYOUT								Approx. Geogrid sq/LF wall (sq m/m wall)	Approx. Paraweb ft/LF wall (m/m wall)	
				Grid Type Specified for Each Layer										
				Vertical Placement (V.P.) of Geogrid Layers Measured Up From Top of Leveling Pad								ft (m)	ft (m)	
				Geogrid Length Measured from the Back of the Blocks								ft (m)	ft (m)	
0 - 4.0 (0 - 1.22)	See Gravity Charts													
5.0 (1.52)	0.5 (0.15)	0.5 (0.15)	16.0 (4.88)	Type V. P. Length	2XT 1.0 (0.30) 3.0 (0.91)	2XT 3.5 (1.07) 3.5 (1.07)							0.7 (1.98)	23.2 (23.20)
6.0 (1.83)	0.5 (0.15)	0.5 (0.15)	16.0 (4.88)	Type V. P. Length	2XT 1.5 (0.46) 3.0 (0.91)	2XT 4.0 (1.22) 4.0 (1.22)							0.8 (2.13)	27.8 (27.84)
7.0 (2.13)	0.5 (0.15)	0.5 (0.15)	16.0 (4.88)	Type V. P. Length	2XT 1.0 (0.30) 3.0 (0.91)	2XT 3.0 (0.91) 3.0 (0.91)	2XT 5.0 (1.52) 4.5 (1.37)						1.2 (3.20)	32.5 (32.48)
8.0 (2.44)	0.5 (0.15)	0.5 (0.15)	16.0 (4.88)	Type V. P. Length	2XT 1.0 (0.30) 4.0 (1.22)	2XT 3.5 (1.07) 4.0 (1.22)	2XT 6.0 (1.83) 5.0 (1.52)						1.4 (3.96)	37.1 (37.12)
9.0 (2.74)	0.5 (0.15)	0.5 (0.15)	16.0 (4.88)	Type V. P. Length	2XT 1.0 (0.30) 4.5 (1.37)	2XT 3.0 (0.91) 4.5 (1.37)	2XT 5.0 (1.52) 4.5 (1.37)	2XT 7.0 (2.13) 5.5 (1.68)					2.1 (5.79)	41.8 (41.76)
10.0 (3.05)	0.5 (0.15)	0.5 (0.15)	16.0 (4.88)	Type V. P. Length	3XT 1.0 (0.30) 5.0 (1.52)	3XT 3.0 (0.91) 5.0 (1.52)	3XT 5.5 (1.68) 5.0 (1.52)	3XT 8.0 (2.44) 6.0 (1.83)					2.3 (6.40)	46.4 (46.40)
11.0 (3.35)	0.67 (0.20)	0.5 (0.15)	16.0 (4.88)	Type V. P. Length	3XT 1.5 (0.46) 6.5 (1.98)	3XT 4.0 (1.22) 6.5 (1.98)	3XT 6.5 (1.98) 6.5 (1.98)	3XT 9.0 (2.74) 6.5 (1.98)					2.9 (7.92)	51.0 (51.04)
12.0 (3.66)	0.67 (0.20)	0.5 (0.15)	16.0 (4.88)	Type V. P. Length	3XT 1.0 (0.30) 7.0 (2.13)	3XT 3.0 (0.91) 7.0 (2.13)	3XT 5.0 (1.52) 7.0 (2.13)	3XT 7.5 (2.29) 7.0 (2.13)	3XT 10.0 (3.05) 7.5 (2.29)				3.9 (10.82)	55.7 (55.68)
13.0 (3.96)	0.75 (0.23)	0.5 (0.15)	16.0 (4.88)	Type V. P. Length	3XT 1.0 (0.30) 7.5 (2.29)	3XT 3.0 (0.91) 7.5 (2.29)	3XT 5.0 (1.52) 7.5 (2.29)	3XT 7.0 (2.13) 7.5 (2.29)	3XT 9.0 (2.74) 7.5 (2.29)	3XT 11.0 (3.35) 8.0 (2.44)			5.1 (13.87)	60.3 (60.32)
14.0 (4.27)	0.75 (0.23)	0.5 (0.15)	16.0 (4.88)	Type V. P. Length	3XT 1.0 (0.30) 8.0 (2.44)	3XT 3.0 (0.91) 8.0 (2.44)	3XT 5.0 (1.52) 8.0 (2.44)	3XT 7.0 (2.13) 8.0 (2.44)	3XT 9.5 (2.90) 8.0 (2.44)	3XT 12.0 (3.66) 9.0 (2.74)			5.4 (14.94)	65.0 (64.96)
15.0 (4.57)	0.75 (0.23)	0.5 (0.15)	16.0 (4.88)	Type V. P. Length	3XT 1.0 (0.30) 9.0 (2.74)	3XT 3.0 (0.91) 9.0 (2.74)	3XT 5.5 (1.68) 9.0 (2.74)	3XT 8.0 (2.44) 9.0 (2.74)	3XT 10.5 (3.20) 9.0 (2.74)	3XT 13.0 (3.96) 9.0 (2.74)			6.0 (16.46)	69.6 (69.60)
Wall heights greater than 15.0' (4.57 m) are achievable.														

NOTES: The above chart was prepared by Rosetta® Hardscapes LLC for estimating and conceptual design purposes only. All information is believed to be true and accurate, however, Rosetta® Hardscapes LLC assumes no responsibility for the use of these design charts for actual construction. Determination of the suitability of each chart is the sole responsibility of the user. **Final designs for construction purposes must be performed by a registered Professional Engineer** using the actual conditions of the proposed site.

1. Unit weight of 28°, 30°, 34° and 40° soils is assumed to be 120pcf (18.9 kN/m3).
2. Minimum factors of safety are 1.5 for sliding, 2.0 for overturning and 2.0 for bearing capacity.
3. Designs are in general accordance with NCMA's *Design Manual for Segmental Retaining Walls (2nd ed.)*.
4. Global stability has not been addressed in these charts.
5. The wall design shall address both internal and external drainage and shall be evaluated by the Professional Engineer who is responsible for the final wall design.
6. Backfill material to be compacted to 95% standard proctor.
7. All Rosetta® Hardscapes LLC Wall System Specifications are to be followed.
8. Each Rosetta® block must be connected into the reinforced soil mass with individual Paraweb® geosynthetic straps. The straps are to be wrapped around the galvanized lift hook on the back of the block.
9. The 6" and 12" high Rosetta® blocks have one galvanized lift hook and require one strap per block. The 18" high and 24" high Rosetta® blocks have two galvanized lift hooks and require two straps per block.
10. Paraweb strap length in chart is total length. Since the strap is looped around the lift hook, the strap extends half the total distance behind the blocks.

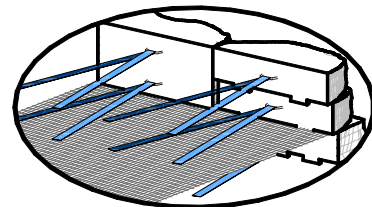

SCHEMATIC STRAP/GRID LAYOUT

- Geogrid Placed Flush to Back of Blocks
- Strap Wrapped Around Lift Hook on Block
- Maintain 3" of Compacted Soil Between Geogrid and Strap (Typ., All Levels)
- Geotextile Fabric and Stone Required Behind Blocks (Not Shown For Clarity)

February 26, 2008

ROSETTA® HARDSCAPES LLC - PRELIMINARY WALL HEIGHT GUIDE

**Silty Sand, Fine to Medium Sand
with an Internal Angle of Friction (ϕ) = 30°**

- Soil Reinforced with Mirafix Miragrid
- Facing Blocks Connected to Reinforced Soil Mass with Paraweb Geosynthetic Strap
- 250 psf (11.96 kPa) Live Load Surcharge, No Back Slope, No Front Slope

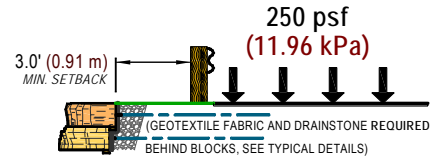

Wall Height ft (m)	Wall Bury Depth ft (m)	Leveling Pad Depth ft (m)	Paraweb 30 Strap Length/Hook ft (m)	GEOGRID LAYOUT						Approx. Geogrid sq/LF wall (sq m/m wall)	Approx. Paraweb ft/LF wall (m/m wall)	
				Type	2XT		3XT		3XT			
Analyze As Gravity Wall												
4.0 (1.22)	0.5 (0.15)	0.5 (0.15)	20.0 (6.10)	Type V. P. Length	2XT 1.0 (0.30) 3.0 (0.91)	2XT 3.0 (0.91) 4.0 (1.22)					0.8 (2.13)	23.2 (23.20)
5.0 (1.52)	0.5 (0.15)	0.5 (0.15)	20.0 (6.10)	Type V. P. Length	2XT 1.0 (0.30) 3.0 (0.91)	2XT 3.5 (1.07) 4.5 (1.37)					0.8 (2.29)	29.0 (29.00)
6.0 (1.83)	0.5 (0.15)	0.5 (0.15)	20.0 (6.10)	Type V. P. Length	2XT 1.5 (0.46) 3.0 (0.91)	2XT 4.0 (1.22) 4.5 (1.37)					0.8 (2.29)	34.8 (34.80)
7.0 (2.13)	0.5 (0.15)	0.5 (0.15)	20.0 (6.10)	Type V. P. Length	2XT 1.0 (0.30) 3.0 (0.91)	2XT 3.0 (0.91) 3.0 (0.91)	2XT 5.0 (1.52) 5.0 (1.52)				1.2 (3.35)	40.6 (40.60)
8.0 (2.44)	0.5 (0.15)	0.5 (0.15)	20.0 (6.10)	Type V. P. Length	2XT 1.0 (0.30) 4.0 (1.22)	2XT 3.5 (1.07) 4.0 (1.22)	2XT 6.0 (1.83) 5.5 (1.68)				1.5 (4.11)	46.4 (46.40)
9.0 (2.74)	0.5 (0.15)	0.5 (0.15)	20.0 (6.10)	Type V. P. Length	2XT 1.0 (0.30) 4.5 (1.37)	2XT 3.0 (0.91) 4.5 (1.37)	2XT 5.0 (1.52) 4.5 (1.37)	2XT 7.0 (2.13) 6.0 (1.83)			2.2 (5.94)	52.2 (52.20)
10.0 (3.05)	0.5 (0.15)	0.5 (0.15)	20.0 (6.10)	Type V. P. Length	3XT 1.0 (0.30) 5.0 (1.52)	3XT 3.0 (0.91) 5.0 (1.52)	3XT 5.5 (1.68) 5.0 (1.52)	3XT 8.0 (2.44) 7.0 (2.13)			2.4 (6.71)	58.0 (58.00)
11.0 (3.35)	0.67 (0.20)	0.5 (0.15)	20.0 (6.10)	Type V. P. Length	3XT 1.5 (0.46) 6.5 (1.98)	3XT 4.0 (1.22) 6.5 (1.98)	3XT 6.5 (1.98) 6.5 (1.98)	3XT 9.0 (2.74) 7.5 (2.29)			3.0 (8.23)	63.8 (63.80)
12.0 (3.66)	0.67 (0.20)	0.5 (0.15)	20.0 (6.10)	Type V. P. Length	3XT 1.0 (0.30) 7.0 (2.13)	3XT 3.0 (0.91) 7.0 (2.13)	3XT 5.0 (1.52) 7.0 (2.13)	3XT 7.5 (2.29) 7.0 (2.13)	3XT 10.0 (3.05) 8.0 (2.44)		4.0 (10.97)	69.6 (69.60)
13.0 (3.96)	0.75 (0.23)	0.5 (0.15)	20.0 (6.10)	Type V. P. Length	3XT 1.0 (0.30) 7.5 (2.29)	3XT 3.0 (0.91) 7.5 (2.29)	3XT 5.0 (1.52) 7.5 (2.29)	3XT 7.0 (2.13) 7.5 (2.29)	3XT 9.0 (2.74) 8.5 (2.59)	3XT 11.0 (3.35)	5.1 (14.02)	75.4 (75.40)
14.0 (4.27)	0.75 (0.23)	0.5 (0.15)	20.0 (6.10)	Type V. P. Length	3XT 1.0 (0.30) 8.0 (2.44)	3XT 3.0 (0.91) 8.0 (2.44)	3XT 5.0 (1.52) 8.0 (2.44)	3XT 7.0 (2.13) 8.0 (2.44)	3XT 9.5 (2.90) 8.0 (2.44)	3XT 12.0 (3.66) 9.0 (2.74)	5.4 (14.94)	81.2 (81.20)
15.0 (4.57)	0.75 (0.23)	0.5 (0.15)	20.0 (6.10)	Type V. P. Length	3XT 1.0 (0.30) 9.0 (2.74)	3XT 3.0 (0.91) 9.0 (2.74)	3XT 5.5 (1.68) 9.0 (2.74)	3XT 8.0 (2.44) 9.0 (2.74)	3XT 10.5 (3.20) 9.0 (2.74)	3XT 13.0 (3.96) 10.0 (3.05)	6.1 (16.76)	87.0 (87.00)
Wall heights greater than 15.0' (4.57 m) are achievable.												

NOTES: The above chart was prepared by Rosetta® Hardscapes LLC for estimating and conceptual design purposes only. All information is believed to be true and accurate, however, Rosetta® Hardscapes LLC assumes no responsibility for the use of these design charts for actual construction. Determination of the suitability of each chart is the sole responsibility of the user. Final designs for construction purposes must be performed by a registered Professional Engineer using the actual conditions of the proposed site.

1. Unit weight of 28°, 30°, 34° and 40° soils is assumed to be 120pcf (18.9 kN/m3).
2. Minimum factors of safety are 1.5 for sliding, 2.0 for overturning and 2.0 for bearing capacity.
3. Designs are in general accordance with NCMA's *Design Manual for Segmental Retaining Walls (2nd ed.)*.
4. Global stability has not been addressed in these charts.
5. The wall design shall address both internal and external drainage and shall be evaluated by the Professional Engineer who is responsible for the final wall design.
6. Backfill material to be compacted to 95% standard proctor.
7. All Rosetta® Hardscapes LLC Wall System Specifications are to be followed.
8. Each Rosetta® block must be connected into the reinforced soil mass with individual Paraweb® geosynthetic straps. The straps are to be wrapped around the galvanized lift hook on the back of the block.
9. The 6" and 12" high Rosetta® blocks have one galvanized lift hook and require one strap per block. The 18" high and 24" high Rosetta® blocks have two galvanized lift hooks and require two straps per block.
10. Paraweb strap length in chart is total length. Since the strap is looped around the lift hook, the strap extends half the total distance behind the blocks.

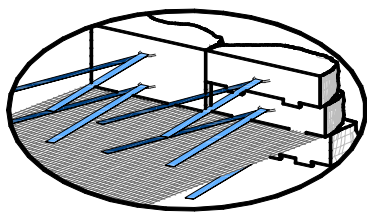

SCHEMATIC STRAP/GRID LAYOUT

- Geogrid Placed Flush to Back of Blocks
- Strap Wrapped Around Lift Hook on Block
- Maintain 3" of Compacted Soil Between Geogrid and Strap (Typ., All Levels)
- Geotextile Fabric and Stone Required Behind Blocks (Not Shown For Clarity)

February 26, 2008

ROSETTA® HARDSCAPES LLC - PRELIMINARY WALL HEIGHT GUIDE

**Silty Sand, Fine to Medium Sand
with an Internal Angle of Friction (ϕ) = 30°**

- Soil Reinforced with Mirafi Miragrid
- Facing Blocks Connected to Reinforced Soil Mass with Paraweb Geosynthetic Strap
- 1:2.5 (21.8°) Back Slope, No Surcharge, No Front Slope

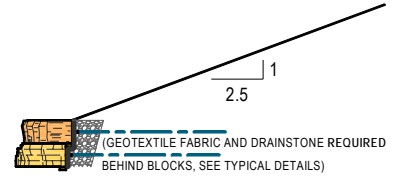

Wall Height ft (m)	Wall Bury Depth ft (m)	Leveling Pad Depth ft (m)	Paraweb 30 Strap Length/Hook ft (m)	GEOGRID LAYOUT								Approx. syd/LF wall (sq m/m wall)	Approx. ft/LF wall (m/m wall)	
				Grid Type Specified for Each Layer										
				Vertical Placement (V.P.) of Geogrid Layers Measured Up From Top of Leveling Pad								ft (m)	ft (m)	
				Geogrid Length Measured from the Back of the Blocks								ft (m)	ft (m)	
0 - 4.0 (0 - 1.22)	See Gravity Charts													
5.0 (1.52)	0.5 (0.15)	0.5 (0.15)	18.0 (5.49)	Type	2XT	2XT							0.9 (2.44)	26.1 (26.10)
				V. P.	1.5 (0.46)	3.5 (1.07)								
6.0 (1.83)	0.5 (0.15)	0.5 (0.15)	18.0 (5.49)	Type	2XT	2XT							1.1 (3.05)	31.3 (31.32)
				V. P.	1.5 (0.46)	4.0 (1.22)								
7.0 (2.13)	0.5 (0.15)	0.5 (0.15)	18.0 (5.49)	Type	2XT	2XT	2XT						2.3 (6.40)	36.5 (36.54)
				V. P.	1.0 (0.30)	3.5 (1.07)	6.0 (1.83)							
8.0 (2.44)	0.5 (0.15)	0.5 (0.15)	18.0 (5.49)	Type	2XT	2XT	2XT						2.8 (7.77)	41.8 (41.76)
				V. P.	1.0 (0.30)	3.5 (1.07)	6.0 (1.83)							
9.0 (2.74)	0.5 (0.15)	0.5 (0.15)	18.0 (5.49)	Type	2XT	2XT	2XT	2XT					4.2 (11.58)	47.0 (46.98)
				V. P.	1.0 (0.30)	3.0 (0.91)	5.5 (1.68)	8.0 (2.44)						
10.0 (3.05)	0.5 (0.15)	0.5 (0.15)	18.0 (5.49)	Type	3XT	3XT	3XT	3XT					5.1 (14.02)	52.2 (52.20)
				V. P.	1.0 (0.30)	3.5 (1.07)	6.0 (1.83)	8.5 (2.59)						
11.0 (3.35)	0.67 (0.20)	0.5 (0.15)	18.0 (5.49)	Type	3XT	3XT	3XT	3XT	3XT				6.7 (18.29)	57.4 (57.42)
				V. P.	1.0 (0.30)	3.0 (0.91)	5.0 (1.52)	7.5 (2.29)	10.0 (3.05)					
12.0 (3.66)	0.67 (0.20)	0.5 (0.15)	18.0 (5.49)	Type	3XT	3XT	3XT	3XT	3XT	3XT			8.7 (23.77)	62.6 (62.64)
				V. P.	1.0 (0.30)	3.0 (0.91)	5.0 (1.52)	7.0 (2.13)	9.0 (2.74)	11.0 (3.35)				
13.0 (3.96)	0.75 (0.23)	0.5 (0.15)	18.0 (5.49)	Type	3XT	3XT	3XT	3XT	3XT	3XT			9.0 (24.69)	67.9 (67.86)
				V. P.	1.0 (0.30)	3.0 (0.91)	5.0 (1.52)	7.0 (2.13)	9.0 (2.74)	11.0 (3.35)				
14.0 (4.27)	0.75 (0.23)	0.5 (0.15)	18.0 (5.49)	Type	3XT	3XT	3XT	3XT	3XT	3XT	3XT		10.5 (28.80)	73.1 (73.08)
				V. P.	0.5 (0.15)	2.0 (0.61)	3.5 (1.07)	5.5 (1.68)	8.0 (2.44)	10.5 (3.20)	13.0 (3.96)			
15.0 (4.57)	0.75 (0.23)	0.5 (0.15)	18.0 (5.49)	Type	3XT	3XT	3XT	3XT	3XT	3XT	3XT		11.3 (30.94)	78.3 (78.30)
				V. P.	0.5 (0.15)	2.0 (0.61)	3.5 (1.07)	5.5 (1.68)	8.0 (2.44)	10.5 (3.20)	13.0 (3.96)			
Wall heights greater than 15.0' (4.57 m) are achievable.														

- NOTES:** The above chart was prepared by Rosetta® Hardscapes LLC for estimating and conceptual design purposes only. All information is believed to be true and accurate, however, Rosetta® Hardscapes LLC assumes no responsibility for the use of these design charts for actual construction. Determination of the suitability of each chart is the sole responsibility of the user. Final designs for construction purposes must be performed by a registered Professional Engineer using the actual conditions of the proposed site.
1. Unit weight of 28°, 30°, 34° and 40° soils is assumed to be 120pcf (18.9 kN/m3).
 2. Minimum factors of safety are 1.5 for sliding, 2.0 for overturning and 2.0 for bearing capacity.
 3. Designs are in general accordance with NCMA's *Design Manual for Segmental Retaining Walls (2nd ed.)*.
 4. Global stability has not been addressed in these charts.
 5. The wall design shall address both internal and external drainage and shall be evaluated by the Professional Engineer who is responsible for the final wall design.
 6. Backfill material to be compacted to 95% standard proctor.
 7. All Rosetta® Hardscapes LLC Wall System Specifications are to be followed.
 8. Each Rosetta® block must be connected into the reinforced soil mass with individual Paraweb® geosynthetic straps. The straps are to be wrapped around the galvanized lift hook on the back of the block.
 9. The 6" and 12" high Rosetta® blocks have one galvanized lift hook and require one strap per block. The 18" high and 24" high Rosetta® blocks have two galvanized lift hooks and require two straps per block.
 10. Paraweb strap length in chart is total length. Since the strap is looped around the lift hook, the strap extends half the total distance behind the blocks.

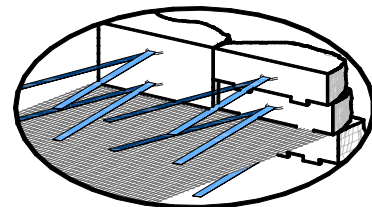

- SCHEMATIC STRAP/GRID LAYOUT**
- Geogrid Placed Flush to Back of Blocks
 - Strap Wrapped Around Lift Hook on Block
 - Maintain 3" of Compacted Soil Between Geogrid and Strap (Typ., All Levels)
 - Geotextile Fabric and Stone Required Behind Blocks (Not Shown For Clarity)

February 26, 2008

ROSETTA® HARDSCAPES LLC - PRELIMINARY WALL HEIGHT GUIDE

**Silty Sand, Clayey Sand
with an Internal Angle of Friction (ϕ) = 28°**

- Soil Reinforced with Mirafi Miragrid
- Facing Blocks Connected to Reinforced Soil Mass with Paraweb Geosynthetic Strap
- No Surcharge, No Back Slope, No Front Slope



Wall Height ft (m)	Wall Bury Depth ft (m)	Leveling Pad Depth ft (m)	Paraweb 30 Strap Length/Hook ft (m)	GEOGRID LAYOUT						Approx. Geogrid syd/LF wall (sq m/m wall)	Approx. Paraweb ft/LF wall (m/m wall)	
				Grid Type Specified for Each Layer								
				Vertical Placement (V.P.) of Geogrid Layers Measured Up From Top of Leveling Pad								
				Geogrid Length Measured from the Back of the Blocks								
0 - 5.0 (0 - 1.52)	See Gravity Charts											
6.0 (1.83)	0.5 (0.15)	0.5 (0.15)	15.0 (4.57)	Type V. P. Length	2XT 1.5 (0.46) 3.0 (0.91)	2XT 4.0 (1.22) 4.0 (1.22)					0.8 (2.13)	26.1 (26.10)
7.0 (2.13)	0.5 (0.15)	0.5 (0.15)	15.0 (4.57)	Type V. P. Length	2XT 1.0 (0.30) 3.0 (0.91)	2XT 3.0 (0.91) 3.0 (0.91)	2XT 5.0 (1.52) 4.5 (1.37)				1.2 (3.20)	30.5 (30.45)
8.0 (2.44)	0.5 (0.15)	0.5 (0.15)	15.0 (4.57)	Type V. P. Length	2XT 1.0 (0.30) 4.0 (1.22)	2XT 3.5 (1.07) 4.0 (1.22)	2XT 6.0 (1.83) 5.0 (1.52)				1.4 (3.96)	34.8 (34.80)
9.0 (2.74)	0.5 (0.15)	0.5 (0.15)	15.0 (4.57)	Type V. P. Length	2XT 1.0 (0.30) 4.5 (1.37)	2XT 3.0 (0.91) 4.5 (1.37)	2XT 5.0 (1.52) 4.5 (1.37)	2XT 7.0 (2.13) 5.5 (1.68)			2.1 (5.79)	39.2 (39.15)
10.0 (3.05)	0.50 (0.15)	0.5 (0.15)	15.0 (4.57)	Type V. P. Length	3XT 1.0 (0.30) 5.0 (1.52)	3XT 3.0 (0.91) 5.0 (1.52)	3XT 5.5 (1.68) 5.0 (1.52)	3XT 8.0 (2.44) 6.0 (1.83)			2.3 (6.40)	43.5 (43.50)
11.0 (3.35)	0.67 (0.20)	0.5 (0.15)	15.0 (4.57)	Type V. P. Length	3XT 1.5 (0.46) 6.5 (1.98)	3XT 4.0 (1.22) 6.5 (1.98)	3XT 6.5 (1.98) 6.5 (1.98)	3XT 9.0 (2.74) 7.0 (2.13)			2.9 (8.08)	47.9 (47.85)
12.0 (3.66)	0.67 (0.20)	0.5 (0.15)	15.0 (4.57)	Type V. P. Length	3XT 1.0 (0.30) 7.0 (2.13)	3XT 3.0 (0.91) 7.0 (2.13)	3XT 5.0 (1.52) 7.0 (2.13)	3XT 7.5 (2.29) 7.0 (2.13)	3XT 10.0 (3.05) 7.5 (2.29)		3.9 (10.82)	52.2 (52.20)
13.0 (3.96)	0.75 (0.23)	0.5 (0.15)	15.0 (4.57)	Type V. P. Length	3XT 1.0 (0.30) 7.5 (2.29)	3XT 3.0 (0.91) 7.5 (2.29)	3XT 5.5 (1.68) 7.5 (2.29)	3XT 8.0 (2.44) 7.5 (2.29)	3XT 10.5 (3.20) 8.0 (2.44)		4.2 (11.58)	56.6 (56.55)
14.0 (4.27)	0.75 (0.23)	0.5 (0.15)	15.0 (4.57)	Type V. P. Length	3XT 1.0 (0.30) 8.0 (2.44)	3XT 3.0 (0.91) 8.0 (2.44)	3XT 5.0 (1.52) 8.0 (2.44)	3XT 7.0 (2.13) 8.0 (2.44)	3XT 9.5 (2.90) 8.5 (2.59)	3XT 12.0 (3.66) 8.5 (2.59)	5.4 (14.78)	60.9 (60.90)
15.0 (4.57)	0.75 (0.23)	0.5 (0.15)	15.0 (4.57)	Type V. P. Length	3XT 1.0 (0.30) 9.0 (2.74)	3XT 3.0 (0.91) 9.0 (2.74)	3XT 5.5 (1.68) 9.0 (2.74)	3XT 8.0 (2.44) 9.0 (2.74)	3XT 10.5 (3.20) 9.0 (2.74)	3XT 13.0 (3.96) 9.0 (2.74)	6.0 (16.46)	65.3 (65.25)
Wall heights greater than 15.0' (4.57 m) are achievable.												

- NOTES:** The above chart was prepared by Rosetta® Hardscapes LLC for estimating and conceptual design purposes only. All information is believed to be true and accurate, however, Rosetta® Hardscapes LLC assumes no responsibility for the use of these design charts for actual construction. Determination of the suitability of each chart is the sole responsibility of the user. **Final designs for construction purposes must be performed by a registered Professional Engineer** using the actual conditions of the proposed site.
1. Unit weight of 28°, 30°, 34° and 40° soils is assumed to be 120pcf (18.9 kN/m3).
 2. Minimum factors of safety are 1.5 for sliding, 2.0 for overturning and 2.0 for bearing capacity.
 3. Designs are in general accordance with NCMA's *Design Manual for Segmental Retaining Walls (2nd ed.)*.
 4. Global stability has not been addressed in these charts.
 5. The wall design shall address both internal and external drainage and shall be evaluated by the Professional Engineer who is responsible for the final wall design.
 6. Backfill material to be compacted to 95% standard proctor.
 7. All Rosetta® Hardscapes LLC Wall System Specifications are to be followed.
 8. Each Rosetta® block must be connected into the reinforced soil mass with individual Paraweb® geosynthetic straps. The straps are to be wrapped around the galvanized lift hook on the back of the block.
 9. The 6" and 12" high Rosetta® blocks have one galvanized lift hook and require one strap per block. The 18" high and 24" high Rosetta® blocks have two galvanized lift hooks and require two straps per block.
 10. Paraweb strap length in chart is total length. Since the strap is looped around the lift hook, the strap extends half the total distance behind the blocks.

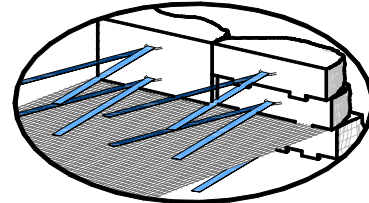

- SCHEMATIC STRAP/GRID LAYOUT**
- Geogrid Placed Flush to Back of Blocks
 - Strap Wrapped Around Lift Hook on Block
 - Maintain 3" of Compacted Soil Between Geogrid and Strap (Typ., All Levels)
 - Geotextile Fabric and Stone Required Behind Blocks (Not Shown For Clarity)

February 26, 2008

ROSETTA® HARDSCAPES LLC - PRELIMINARY WALL HEIGHT GUIDE

**Silty Sand, Clayey Sand
with an Internal Angle of Friction (ϕ) = 28°**

- Soil Reinforced with Mirafi Miragrid
- Facing Blocks Connected to Reinforced Soil Mass with Paraweb Geosynthetic Strap
- 100 psf (4.79 kPa) Live Load Surcharge, No Back Slope, No Front Slope

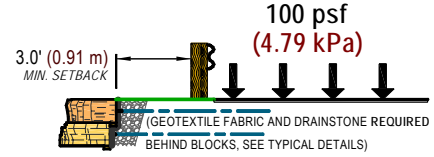

Wall Height ft (m)	Wall Bury Depth ft (m)	Leveling Pad Depth ft (m)	Paraweb 30 Strap Length/Hook ft (m)	GEOGRID LAYOUT								Approx. Geogrid syd/LF wall (sq m/m wall)	Approx. Paraweb ft/LF wall (m/m wall)	
				Grid Type Specified for Each Layer										
				Vertical Placement (V.P.) of Geogrid Layers Measured Up From Top of Leveling Pad										
				Geogrid Length Measured from the Back of the Blocks										
0 - 4.0 (0 - 1.22)	See Gravity Charts													
5.0 (1.52)	0.5 (0.15)	0.5 (0.15)	18.0 (5.49)	Type V. P. Length	2XT 1.0 (0.30) 3.0 (0.91)	2XT 3.5 (1.07) 4.0 (1.22)							0.8 (2.13)	26.1 (26.10)
6.0 (1.83)	0.5 (0.15)	0.5 (0.15)	18.0 (5.49)	Type V. P. Length	2XT 1.5 (0.46) 3.0 (0.91)	2XT 4.0 (1.22) 4.5 (1.37)							0.8 (2.29)	31.3 (31.32)
7.0 (2.13)	0.5 (0.15)	0.5 (0.15)	18.0 (5.49)	Type V. P. Length	2XT 1.0 (0.30) 3.0 (0.91)	2XT 3.0 (0.91) 3.0 (0.91)	2XT 5.0 (1.52) 4.5 (1.37)						1.2 (3.20)	36.5 (36.54)
8.0 (2.44)	0.5 (0.15)	0.5 (0.15)	18.0 (5.49)	Type V. P. Length	2XT 1.0 (0.30) 4.0 (1.22)	2XT 3.5 (1.07) 4.0 (1.22)	2XT 6.0 (1.83) 5.5 (1.68)						1.5 (4.11)	41.8 (41.76)
9.0 (2.74)	0.5 (0.15)	0.5 (0.15)	18.0 (5.49)	Type V. P. Length	2XT 1.0 (0.30) 4.5 (1.37)	2XT 3.0 (0.91) 4.5 (1.37)	2XT 5.0 (1.52) 4.5 (1.37)	2XT 7.0 (2.13) 6.0 (1.83)					2.2 (5.94)	47.0 (46.98)
10.0 (3.05)	0.5 (0.15)	0.5 (0.15)	18.0 (5.49)	Type V. P. Length	3XT 1.0 (0.30) 5.0 (1.52)	3XT 3.0 (0.91) 5.0 (1.52)	3XT 5.5 (1.68) 5.0 (1.52)	3XT 8.0 (2.44) 6.5 (1.98)					2.4 (6.55)	52.2 (52.20)
11.0 (3.35)	0.67 (0.20)	0.5 (0.15)	18.0 (5.49)	Type V. P. Length	3XT 1.5 (0.46) 6.5 (1.98)	3XT 4.0 (1.22) 6.5 (1.98)	3XT 6.5 (1.98) 6.5 (1.98)	3XT 9.0 (2.74) 7.5 (2.29)					3.0 (8.23)	57.4 (57.42)
12.0 (3.66)	0.67 (0.20)	0.5 (0.15)	18.0 (5.49)	Type V. P. Length	3XT 1.0 (0.30) 7.0 (2.13)	3XT 3.0 (0.91) 7.0 (2.13)	3XT 5.0 (1.52) 7.0 (2.13)	3XT 7.5 (2.29) 7.0 (2.13)	3XT 10.0 (3.05) 8.0 (2.44)				4.0 (10.97)	62.6 (62.64)
13.0 (3.96)	0.75 (0.23)	0.5 (0.15)	18.0 (5.49)	Type V. P. Length	3XT 1.0 (0.30) 7.5 (2.29)	3XT 3.0 (0.91) 7.5 (2.29)	3XT 5.0 (1.52) 7.5 (2.29)	3XT 7.0 (2.13) 7.5 (2.29)	3XT 9.0 (2.74) 7.5 (2.29)	3XT 11.0 (3.35) 8.5 (2.59)			5.1 (14.02)	67.9 (67.86)
14.0 (4.27)	0.75 (0.23)	0.5 (0.15)	18.0 (5.49)	Type V. P. Length	3XT 1.0 (0.30) 8.0 (2.44)	3XT 3.0 (0.91) 8.0 (2.44)	3XT 5.0 (1.52) 8.0 (2.44)	3XT 7.0 (2.13) 8.0 (2.44)	3XT 9.5 (2.90) 8.0 (2.44)	3XT 12.0 (3.66) 9.0 (2.74)			5.4 (14.94)	73.1 (73.08)
15.0 (4.57)	0.75 (0.23)	0.5 (0.15)	18.0 (5.49)	Type V. P. Length	3XT 1.0 (0.30) 9.0 (2.74)	3XT 3.0 (0.91) 9.0 (2.74)	3XT 5.5 (1.68) 9.0 (2.74)	3XT 8.0 (2.44) 9.0 (2.74)	3XT 10.5 (3.20) 9.0 (2.74)	3XT 13.0 (3.96) 10.0 (3.05)			6.1 (16.76)	78.3 (78.30)
Wall heights greater than 15.0' (4.57 m) are achievable.														

NOTES: The above chart was prepared by Rosetta® Hardscapes LLC for estimating and conceptual design purposes only. All information is believed to be true and accurate, however, Rosetta® Hardscapes LLC assumes no responsibility for the use of these design charts for actual construction. Determination of the suitability of each chart is the sole responsibility of the user. Final designs for construction purposes must be performed by a registered Professional Engineer using the actual conditions of the proposed site.

1. Unit weight of 28°, 30°, 34° and 40° soils is assumed to be 120pcf (18.9 kN/m3).
2. Minimum factors of safety are 1.5 for sliding, 2.0 for overturning and 2.0 for bearing capacity.
3. Designs are in general accordance with NCMA's *Design Manual for Segmental Retaining Walls (2nd ed.)*.
4. Global stability has not been addressed in these charts.
5. The wall design shall address both internal and external drainage and shall be evaluated by the Professional Engineer who is responsible for the final wall design.
6. Backfill material to be compacted to 95% standard proctor.
7. All Rosetta® Hardscapes LLC Wall System Specifications are to be followed.
8. Each Rosetta® block must be connected into the reinforced soil mass with individual Paraweb® geosynthetic straps. The straps are to be wrapped around the galvanized lift hook on the back of the block.
9. The 6" and 12" high Rosetta® blocks have one galvanized lift hook and require one strap per block. The 18" high and 24" high Rosetta® blocks have two galvanized lift hooks and require two straps per block.
10. Paraweb strap length in chart is total length. Since the strap is looped around the lift hook, the strap extends half the total distance behind the blocks.

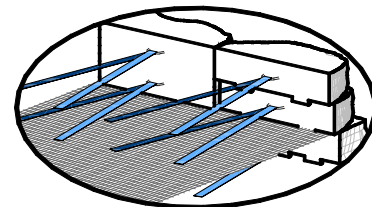

SCHEMATIC STRAP/GRID LAYOUT

- Geogrid Placed Flush to Back of Blocks
- Strap Wrapped Around Lift Hook on Block
- Maintain 3" of Compacted Soil Between Geogrid and Strap (Typ., All Levels)
- Geotextile Fabric and Stone Required Behind Blocks (Not Shown For Clarity)

February 26, 2008

ROSETTA® HARDSCAPES LLC - PRELIMINARY WALL HEIGHT GUIDE

**Silty Sand, Clayey Sand
with an Internal Angle of Friction (φ) = 28°**

- Soil Reinforced with Mirafi Miragrid
- Facing Blocks Connected to Reinforced Soil Mass with Paraweb Geosynthetic Strap
- 250 psf (11.96 kPa) Live Load Surcharge, No Back Slope, No Front Slope

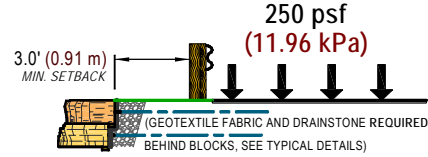

Wall Height ft (m)	Wall Bury Depth ft (m)	Leveling Pad Depth ft (m)	Paraweb 30 Strap Length/Hook ft (m)	GEOGRID LAYOUT										Approx. Geogrid syd/LF wall (sq m/m wall)	Approx. Paraweb ft/LF wall (m/m wall)	
				Grid Type Specified for Each Layer												
				Vertical Placement (V.P.) of Geogrid Layers Measured Up From Top of Leveling Pad												
				Geogrid Length Measured from the Back of the Blocks												
0 - 3.0 (0 - 0.91)	Analyze As Gravity Wall															
4.0 (1.22)	0.5 (0.15)	0.5 (0.15)	24.0 (7.32)	Type V. P. Length	2XT 1.0 (0.30) 3.0 (0.91)	2XT 3.0 (0.91) 4.5 (1.37)									0.8 (2.29)	27.8 (27.84)
5.0 (1.52)	0.5 (0.15)	0.5 (0.15)	24.0 (7.32)	Type V. P. Length	2XT 1.0 (0.30) 3.0 (0.91)	2XT 3.5 (1.07) 5.0 (1.52)									0.9 (2.44)	34.8 (34.80)
6.0 (1.83)	0.5 (0.15)	0.5 (0.15)	24.0 (7.32)	Type V. P. Length	2XT 1.5 (0.46) 3.0 (0.91)	2XT 4.0 (1.22) 5.0 (1.52)									0.9 (2.44)	41.8 (41.76)
7.0 (2.13)	0.5 (0.15)	0.5 (0.15)	24.0 (7.32)	Type V. P. Length	2XT 1.0 (0.30) 3.0 (0.91)	2XT 3.0 (0.91) 3.5 (1.07)	2XT 5.0 (1.52) 5.5 (1.68)								1.3 (3.66)	48.7 (48.72)
8.0 (2.44)	0.5 (0.15)	0.5 (0.15)	24.0 (7.32)	Type V. P. Length	2XT 1.0 (0.30) 4.0 (1.22)	2XT 3.5 (1.07) 4.0 (1.22)	2XT 6.0 (1.83) 6.5 (1.98)								1.6 (4.42)	55.7 (55.68)
9.0 (2.74)	0.5 (0.15)	0.5 (0.15)	24.0 (7.32)	Type V. P. Length	2XT 1.0 (0.30) 4.5 (1.37)	2XT 3.0 (0.91) 4.5 (1.37)	2XT 5.0 (1.52) 4.5 (1.37)	2XT 7.0 (2.13) 6.5 (1.98)							2.2 (6.10)	62.6 (62.64)
10.0 (3.05)	0.5 (0.15)	0.5 (0.15)	24.0 (7.32)	Type V. P. Length	3XT 1.0 (0.30) 5.5 (1.68)	3XT 3.0 (0.91) 5.5 (1.68)	3XT 5.5 (1.68) 5.5 (1.68)	3XT 8.0 (2.44) 7.5 (2.29)							2.7 (7.32)	69.6 (69.60)
11.0 (3.35)	0.67 (0.20)	0.5 (0.15)	24.0 (7.32)	Type V. P. Length	3XT 1.0 (0.30) 6.5 (1.98)	3XT 3.0 (0.91) 6.5 (1.98)	3XT 5.0 (1.52) 6.5 (1.98)	3XT 7.0 (2.13) 6.5 (1.98)	3XT 9.0 (2.74) 8.0 (2.44)						3.8 (10.36)	76.6 (76.56)
12.0 (3.66)	0.67 (0.20)	0.5 (0.15)	24.0 (7.32)	Type V. P. Length	3XT 1.0 (0.30) 7.5 (2.29)	3XT 3.0 (0.91) 7.5 (2.29)	3XT 5.0 (1.52) 7.5 (2.29)	3XT 7.5 (2.29) 7.5 (2.29)	3XT 10.0 (3.05) 9.0 (2.74)						4.3 (11.89)	83.5 (83.52)
13.0 (3.96)	0.75 (0.23)	0.5 (0.15)	24.0 (7.32)	Type V. P. Length	3XT 1.0 (0.30) 8.0 (2.44)	3XT 3.0 (0.91) 8.0 (2.44)	3XT 5.0 (1.52) 8.0 (2.44)	3XT 7.0 (2.13) 8.0 (2.44)	3XT 9.0 (2.74) 8.0 (2.44)	3XT 11.0 (3.35) 9.0 (2.74)					5.4 (14.94)	90.5 (90.48)
14.0 (4.27)	0.75 (0.23)	0.5 (0.15)	24.0 (7.32)	Type V. P. Length	3XT 1.0 (0.30) 9.0 (2.74)	3XT 3.0 (0.91) 9.0 (2.74)	3XT 5.0 (1.52) 9.0 (2.74)	3XT 7.0 (2.13) 9.0 (2.74)	3XT 9.5 (2.90) 9.0 (2.74)	3XT 12.0 (3.66) 10.0 (3.05)					6.1 (16.76)	97.4 (97.44)
15.0 (4.57)	0.75 (0.23)	0.5 (0.15)	24.0 (7.32)	Type V. P. Length	3XT 0.5 (0.15) 9.0 (2.74)	3XT 2.0 (0.61) 9.0 (2.74)	3XT 3.5 (1.07) 9.0 (2.74)	3XT 5.5 (1.68) 9.0 (2.74)	3XT 8.0 (2.44) 9.0 (2.74)	3XT 10.5 (3.20) 9.0 (2.74)	3XT 13.0 (3.96) 10.5 (3.20)				7.2 (19.66)	104.4 (104.40)
Wall heights greater than 15.0' (4.57 m) are achievable.																

- NOTES:** The above chart was prepared by Rosetta® Hardscapes LLC for estimating and conceptual design purposes only. All information is believed to be true and accurate, however, Rosetta® Hardscapes LLC assumes no responsibility for the use of these design charts for actual construction. Determination of the suitability of each chart is the sole responsibility of the user. Final designs for construction purposes must be performed by a registered Professional Engineer using the actual conditions of the proposed site.
1. Unit weight of 28°, 30°, 34° and 40° soils is assumed to be 120pcf (18.9 kN/m3).
 2. Minimum factors of safety are 1.5 for sliding, 2.0 for overturning and 2.0 for bearing capacity.
 3. Designs are in general accordance with NCMA's *Design Manual for Segmental Retaining Walls (2nd ed.)*.
 4. Global stability has not been addressed in these charts.
 5. The wall design shall address both internal and external drainage and shall be evaluated by the Professional Engineer who is responsible for the final wall design.
 6. Backfill material to be compacted to 95% standard proctor.
 7. All Rosetta® Hardscapes LLC Wall System Specifications are to be followed.
 8. Each Rosetta® block must be connected into the reinforced soil mass with individual Paraweb® geosynthetic straps. The straps are to be wrapped around the galvanized lift hook on the back of the block.
 9. The 6" and 12" high Rosetta® blocks have one galvanized lift hook and require one strap per block. The 18" high and 24" high Rosetta® blocks have two galvanized lift hooks and require two straps per block.
 10. Paraweb strap length in chart is total length. Since the strap is looped around the lift hook, the strap extends half the total distance behind the blocks.

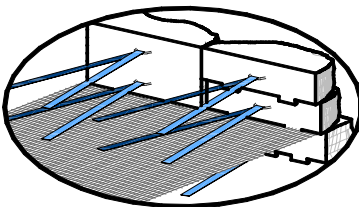

- SCHEMATIC STRAP/GRID LAYOUT**
- Geogrid Placed Flush to Back of Blocks
 - Strap Wrapped Around Lift Hook on Block
 - Maintain 3" of Compacted Soil Between Geogrid and Strap (Typ., All Levels)
 - Geotextile Fabric and Stone Required Behind Blocks (Not Shown For Clarity)

February 26, 2008

ROSETTA® HARDSCAPES LLC - PRELIMINARY WALL HEIGHT GUIDE

**Silty Sand, Clayey Sand
with an Internal Angle of Friction (ϕ) = 28°**

- Soil Reinforced with Mirafi Miragrid
- Facing Blocks Connected to Reinforced Soil Mass with Paraweb Geosynthetic Strap
- 1:2.5 (21.8°) Back Slope, No Surcharge, No Front Slope

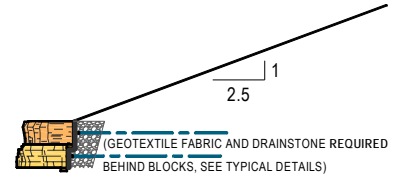

Wall Height ft (m)	Wall Bury Depth ft (m)	Leveling Pad Depth ft (m)	Paraweb 30 Strap Length/Hook ft (m)	GEOGRID LAYOUT Grid Type Specified for Each Layer Vertical Placement (V.P.) of Geogrid Layers Measured Up From Top of Leveling Pad ft (m) Geogrid Length Measured from the Back of the Blocks ft (m)								Approx. Geogrid syd/LF wall (sq m/m wall)	Approx. Paraweb ft/LF wall (m/m wall)	
0 - 4.0 (0 - 1.22)	See Gravity Charts													
5.0 (1.52)	0.5 (0.15)	0.5 (0.15)	21.0 (6.40)	Type V. P. Length	2XT 1.5 (0.46) 3.5 (1.07)	2XT 3.5 (1.07) 4.5 (1.37)							0.9 (2.44)	30.5 (30.45)
6.0 (1.83)	0.5 (0.15)	0.5 (0.15)	21.0 (6.40)	Type V. P. Length	2XT 1.5 (0.46) 5.0 (1.52)	2XT 4.0 (1.22) 5.0 (1.52)							1.1 (3.05)	36.5 (36.54)
7.0 (2.13)	0.5 (0.15)	0.5 (0.15)	21.0 (6.40)	Type V. P. Length	2XT 1.5 (0.46) 9.0 (2.74)	2XT 3.5 (1.07) 9.0 (2.74)	2XT 6.0 (1.83) 9.0 (2.74)						3.0 (8.23)	42.6 (42.63)
8.0 (2.44)	0.5 (0.15)	0.5 (0.15)	21.0 (6.40)	Type V. P. Length	2XT 1.0 (0.30) 14.5 (4.42)	2XT 3.5 (1.07) 14.5 (4.42)	2XT 6.0 (1.83) 14.5 (4.42)						4.8 (13.26)	48.7 (48.72)
9.0 (2.74)	0.5 (0.15)	0.5 (0.15)	21.0 (6.40)	Type V. P. Length	2XT 1.0 (0.30) 15.0 (4.57)	2XT 3.0 (0.91) 15.0 (4.57)	2XT 5.5 (1.68) 15.0 (4.57)	2XT 8.0 (2.44) 15.0 (4.57)					6.7 (18.29)	54.8 (54.81)
10.0 (3.05)	0.5 (0.15)	0.5 (0.15)	21.0 (6.40)	Type V. P. Length	3XT 0.5 (0.15) 16.0 (4.88)	3XT 3.0 (0.91) 16.0 (4.88)	3XT 5.5 (1.68) 16.0 (4.88)	3XT 8.0 (2.44) 16.0 (4.88)					7.1 (19.51)	60.9 (60.90)
11.0 (3.35)	0.67 (0.20)	0.5 (0.15)	21.0 (6.40)	Type V. P. Length	3XT 0.5 (0.15) 16.0 (4.88)	3XT 2.5 (0.76) 16.0 (4.88)	3XT 4.5 (1.37) 16.0 (4.88)	3XT 6.5 (1.98) 16.0 (4.88)	3XT 9.0 (2.74) 16.0 (4.88)				8.9 (24.38)	67.0 (66.99)
12.0 (3.66)	0.67 (0.20)	0.5 (0.15)	21.0 (6.40)	Type V. P. Length	3XT 0.5 (0.15) 16.0 (4.88)	3XT 2.0 (0.61) 16.0 (4.88)	3XT 3.5 (1.07) 16.0 (4.88)	3XT 5.5 (1.68) 16.0 (4.88)	3XT 7.5 (2.29) 16.0 (4.88)	3XT 10.0 (3.05) 16.0 (4.88)			10.7 (29.26)	73.1 (73.08)
13.0 (3.96)	0.75 (0.23)	0.5 (0.15)	21.0 (6.40)	Type V. P. Length	3XT 0.5 (0.15) 17.5 (5.33)	3XT 2.0 (0.61) 17.5 (5.33)	3XT 3.5 (1.07) 17.5 (5.33)	3XT 6.0 (1.83) 17.5 (5.33)	3XT 8.5 (2.59) 17.5 (5.33)	3XT 11.0 (3.35) 17.5 (5.33)			11.7 (32.00)	79.2 (79.17)
14.0 (4.27)	0.75 (0.23)	0.5 (0.15)	21.0 (6.40)	Type V. P. Length	3XT 0.5 (0.15) 18.0 (5.49)	3XT 2.0 (0.61) 18.0 (5.49)	3XT 3.5 (1.07) 18.0 (5.49)	3XT 5.5 (1.68) 18.0 (5.49)	3XT 8.0 (2.44) 18.0 (5.49)	3XT 10.5 (3.20) 18.0 (5.49)	3XT 13.0 (3.96) 18.0 (5.49)		14.0 (38.40)	85.3 (85.26)
Wall heights greater than 14.0' (4.27 m) are achievable.														

- NOTES: The above chart was prepared by Rosetta® Hardscapes LLC for estimating and conceptual design purposes only. All information is believed to be true and accurate, however, Rosetta® Hardscapes LLC assumes no responsibility for the use of these design charts for actual construction. Determination of the suitability of each chart is the sole responsibility of the user. Final designs for construction purposes must be performed by a registered Professional Engineer using the actual conditions of the proposed site.
1. Unit weight of 28°, 30°, 34° and 40° soils is assumed to be 120pcf (18.9 kN/m3).
 2. Minimum factors of safety are 1.5 for sliding, 2.0 for overturning and 2.0 for bearing capacity.
 3. Designs are in general accordance with NCMA's *Design Manual for Segmental Retaining Walls (2nd ed.)*.
 4. Global stability has not been addressed in these charts.
 5. The wall design shall address both internal and external drainage and shall be evaluated by the Professional Engineer who is responsible for the final wall design.
 6. Backfill material to be compacted to 95% standard proctor.
 7. All Rosetta® Hardscapes LLC Wall System Specifications are to be followed.
 8. Each Rosetta® block must be connected into the reinforced soil mass with individual Paraweb® geosynthetic straps. The straps are to be wrapped around the galvanized lift hook on the back of the block.
 9. The 6" and 12" high Rosetta® blocks have one galvanized lift hook and require one strap per block. The 18" high and 24" high Rosetta® blocks have two galvanized lift hooks and require two straps per block.
 10. Paraweb strap length in chart is total length. Since the strap is looped around the lift hook, the strap extends half the total distance behind the blocks.

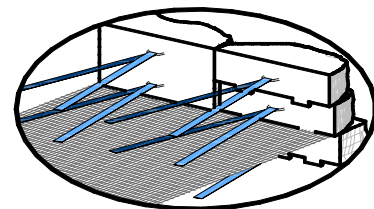

- SCHEMATIC STRAP/GRID LAYOUT**
- Geogrid Placed Flush to Back of Blocks
 - Strap Wrapped Around Lift Hook on Block
 - Maintain 3" of Compacted Soil Between Geogrid and Strap (Typ., All Levels)
 - Geotextile Fabric and Stone Required Behind Blocks (Not Shown For Clarity)

February 26, 2008

**TYPICAL CONNECTION OF 6" OR 12" (15.2 cm or 30.5 cm) HIGH
ROSETTA BLOCKS AND PARAWEB STRAP**

(NO SCALE)

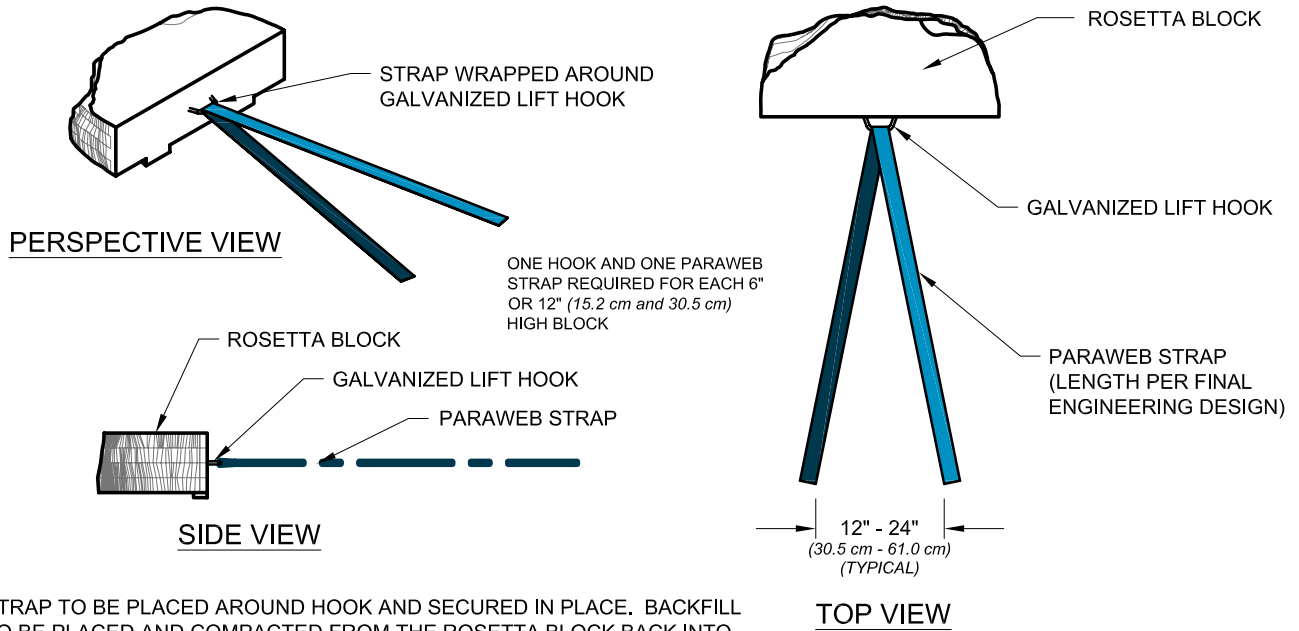

STRAP TO BE PLACED AROUND HOOK AND SECURED IN PLACE. BACKFILL TO BE PLACED AND COMPACTED FROM THE ROSETTA BLOCK BACK INTO THE REINFORCED SOIL ZONE TO AVOID "BUNCHING" OF THE STRAP.

**TYPICAL CONNECTION OF 18" OR 24" (45.7 cm or 61.0 cm) HIGH
ROSETTA BLOCKS AND PARAWEB STRAP**

(NO SCALE)

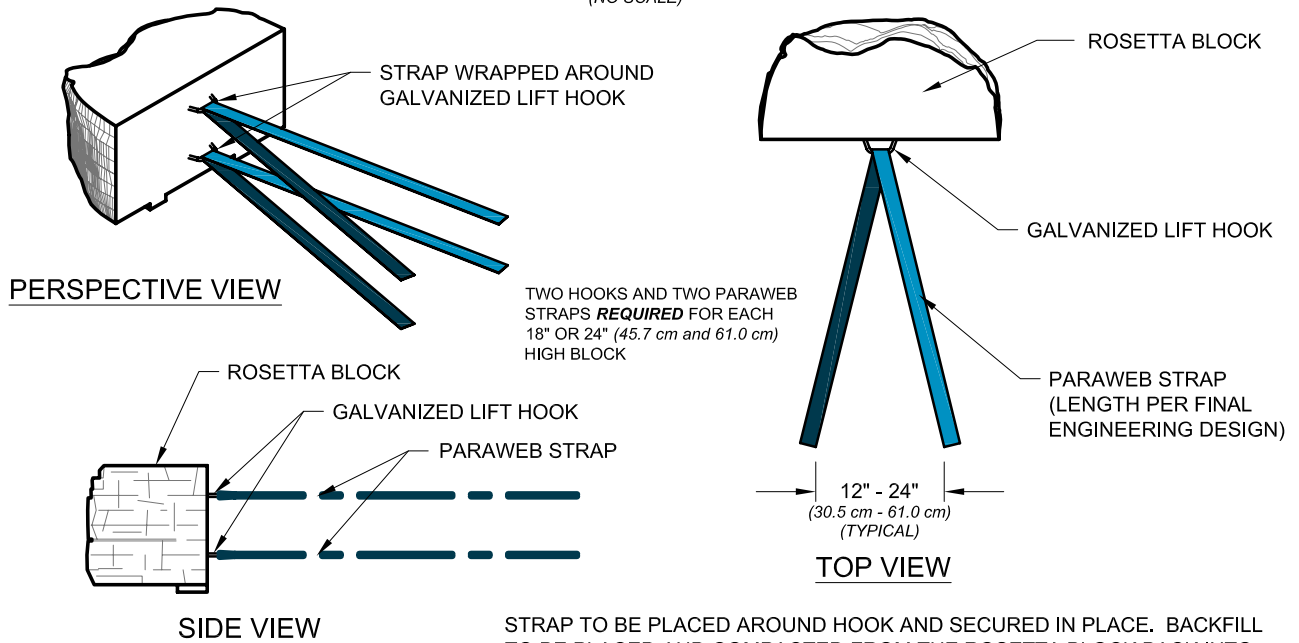

STRAP TO BE PLACED AROUND HOOK AND SECURED IN PLACE. BACKFILL TO BE PLACED AND COMPACTED FROM THE ROSETTA BLOCK BACK INTO THE REINFORCED SOIL ZONE TO AVOID "BUNCHING" OF THE STRAP.

DRAWN BY: J. Johnson	TITLE: TYPICAL PARAWEB STRAP CONNECTION TO A ROSETTA HARDSCAPES BLOCK
APPROVED BY:	
DATE: February 28, 2008	DRAWING FILE: Strap Connection - Typical Detail.dwg

TITLE: TYPICAL PARAWEB STRAP CONNECTION TO A ROSETTA HARDSCAPES BLOCK
DRAWING FILE: Strap Connection - Typical Detail.dwg

ROSETTA
HARDSCAPES, LLC

05481 US 31 SOUTH CHARLEVOIX, MI 49720
877-777-6558 • 231-237-9656 Fax • www.discoverrosetta.com

ROSETTA
HARDSCAPES, LLC
 05481 US 31 SOUTH CHARLEVOIX, MI 49720
 877-777-6558 • 231-237-9656 Fax • www.discoverrosetta.com

PROJECT:
 SAMPLE STRAP LENGTH CALCULATIONS

SHEET:
 1 OF 2

PREPARED BY:
 ROSETTA HARDSCAPES

DATE:
 12-21-07

STRAP LENGTH CALCULATIONS FOR 34° SOIL, 250 PSF LIVE LOAD SURCHARGE (WITH A 3.0' MIN. SETBACK FROM THE TOP OF THE WALL), NO BACK SLOPE, NO FRONT SLOPE.

ROSETTA BLOCKS

STRAP DESIGNED FOR 12"X6' BLOCK
 (LARGEST BLOCK AREA PER SINGLE LIFT HOOK)
 $H_{BLOCK} = 12"$
 $L_{BLOCK} = 6'$
 $W_{BLOCK} = 18"$ (CALCULATED BLOCK WIDTH / THEORETICAL TOE LOCATION)
 $G_U = 8.6"$ (FROM THEORETICAL TOE)
 WALL BATTER = 3" HORIZONTAL/12" VERTICAL, $\omega = 14.0^\circ$

REINFORCED SOIL PROPERTIES

$\phi_1 = 34^\circ$
 $\gamma_1 = 120$ PCF
 $\delta_1 = \frac{2}{3} \phi_1 = 22.7^\circ$
 $K_A = 0.167$
 $K_{AH} = K_A \cos(\delta_1 - \omega) = 0.165$
 $\alpha_1 = 52.9^\circ$

PARAWEB 30 STRAP (VALUES PUBLISHED BY LINEAR COMPOSITES)

$W_S = 3.25"$ $RF_D = 1.05$ $FS_{UNC} = 1.5$
 $T_{ULT} = 6744$ LB $RF_{ID} = 1.04$ (SAND) $T_{ALLOW} = T_{ULT}/RF_D RF_{ID} RF_{CR} FS_{UNC} = 2656$ LB
 $C_i = 0.8$ (34° SOIL) $RF_{CR} = 1.55$

HORIZONTAL EARTH PRESSURE LOAD ON THE FACING BLOCK

THE FORCE ACTING ON THE FACING BLOCK:

$$F_{PO} = K_{AH} \times \sigma_N \times A_{BLOCK} = K_{AH} \times (\text{DEPTH}_{MIDDLE OF BLOCK} \times \gamma_1 + Q_{DL} + Q_{LL}) \times A_{BLOCK}$$

THE INCREASED PRESSURE ACTING ON THE WALL FROM THE LIVE LOAD SURCHARGE (Q_{LL}) IS CALCULATED USING THE METHOD OUTLINED IN THE US ARMY CORPS OF ENGINEERS EM 1110-2-2502.

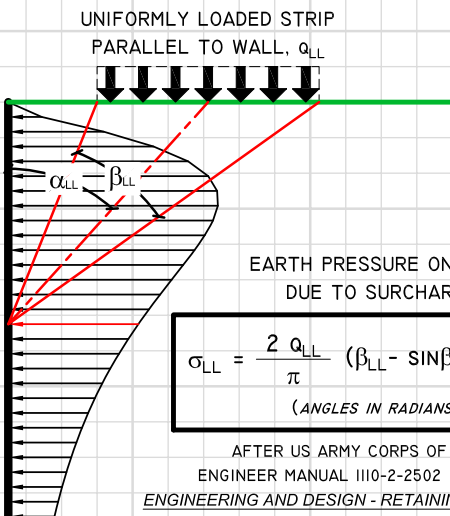

FOR THE TOP BLOCK WITH A 3' SETBACK
 AND A 50' WIDE SURCHARGE AREA,
 $\alpha_{LL} = 1.5529$ AND $\beta_{LL} = 0.1557$

$$\sigma_{LL} = \frac{2 \times 250}{\pi} (0.1557 - \sin 0.1557 \times \cos 3.1058)$$

$$\sigma_{LL} = 49.4 \text{ PSF}$$

AND THE FORCE ACTING ON THE TOP BLOCK IS:

$$F_{PO} = K_{AH} \times \sigma_N \times A_{BLOCK} = K_{AH} \times (\text{DEPTH}_{MIDDLE OF BLOCK} \times \gamma_1 + Q_{DL} + Q_{LL}) \times A_{BLOCK}$$

$$= 0.165 \times (0.5 \times 120 + 0 + 49.4) \times 6$$

$$= \underline{108.3 \text{ LB}}$$

STRAP LENGTH CALCULATIONS FOR 34° SOIL, 250 PSF LIVE LOAD SURCHARGE (WITH A 3.0' MIN. SETBACK FROM THE TOP OF THE WALL), NO BACK SLOPE, NO FRONT SLOPE.

PARAWEB STRAP CONNECTION

FOR REINFORCED SOIL WALLS, INDIVIDUAL ROSETTA FACING BLOCKS ARE HELD IN PLACE WITH PARAWEB GEOSYNTHETIC STRAP. THE STRAP IS LOOPED AROUND A GALVANIZED LIFT HOOK CAST INTO THE BACK OF THE ROSETTA BLOCKS. THERE IS ONE LIFT HOOK (AND STRAP CONNECTION) IN 6" AND 12" HIGH ROSETTA BLOCKS AND TWO LIFT HOOKS (AND STRAP CONNECTIONS) IN 18" AND 24" HIGH ROSETTA BLOCKS.

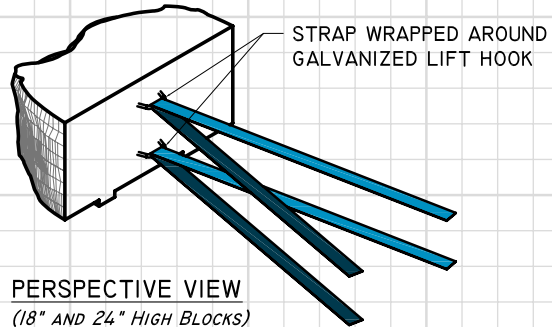
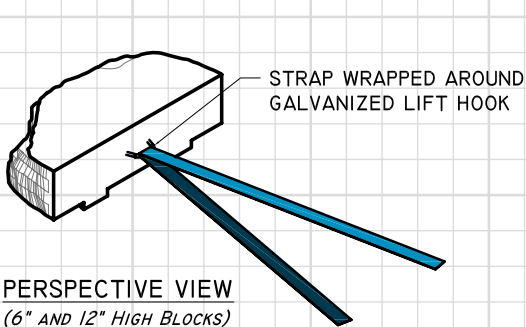

LENGTH OF PARAWEB STRAP TO RESIST PULLOUT FROM THE SOIL

CAPACITY OF THE INDIVIDUAL PARAWEB STRAP TO RESIST PULLOUT:

$$R_{PO} = C_1 \times L_E \times W_s \times 2 \text{ LEGS/HOOK} \times 2 \text{ SIDES/LEG} \times \sigma_N \text{ (DEAD LOAD COMPONENT ONLY)} \times \tan \phi_i$$

FOR THE STRAP RESISTING PULLOUT ON THE TOP BLOCK:

$$R_{PO} = 0.8 \times L_E \times 0.271' \times 2 \text{ LEGS/HOOK} \times 2 \text{ SIDES/LEG} \times (0.5 \times 120) \times \tan 34^\circ$$

$$= 35.1 \times L_E \text{ LB}$$

SETTING $R_{PO} = F_{PO} \times 1.5$ (FACTOR OF SAFETY), RESULTS IN $L_E = 4.6 \text{ FT.}$

ADDITIONAL CALCULATIONS FOR LOWER BLOCKS IN THE WALL SHOW THIS L_E TO BE THE LONGEST REQUIRED STRAP EMBEDMENT LENGTH. FOR TYPICAL CONSTRUCTION, THIS LENGTH OF STRAP IS USED ON ALL BLOCKS IN THE WALL.

LENGTH OF PARAWEB STRAP IN THE ACTIVE ZONE

ADDITIONAL STRAP IS REQUIRED TO INSURE L_E IS LOCATED BEYOND THE LOCAL FAILURE SURFACE BETWEEN GEOGRID LAYERS. THE LENGTH OF STRAP IN THE ACTIVE ZONE, L_A IS CALCULATED BY:

$$L_A = \text{GEOGRID LAYER VERTICAL SPACING} / \tan \alpha_i$$

WITH A 30" MAXIMUM SPACING BETWEEN GEOGRID LAYERS:

$$L_A = 30" / \tan 52.9^\circ = 1.9 \text{ FT}$$

TOTAL STRAP LENGTH

THE STRAP REQUIRED FOR EACH BLOCK IS THE SUM OF THE EMBEDMENT AND ACTIVE LENGTHS:

$$L_{MIN} = L_E + L_A$$

$$= 4.6 \text{ FT} + 1.9 \text{ FT}$$

$$= \boxed{6.5 \text{ FT / LEG OR 13 FT / HOOK}}$$

(NOTE: THIS IS THE STRAP LENGTH SHOWN IN THE ROSETTA HARDSCAPES PRELIMINARY WALL HEIGHT GUIDE)

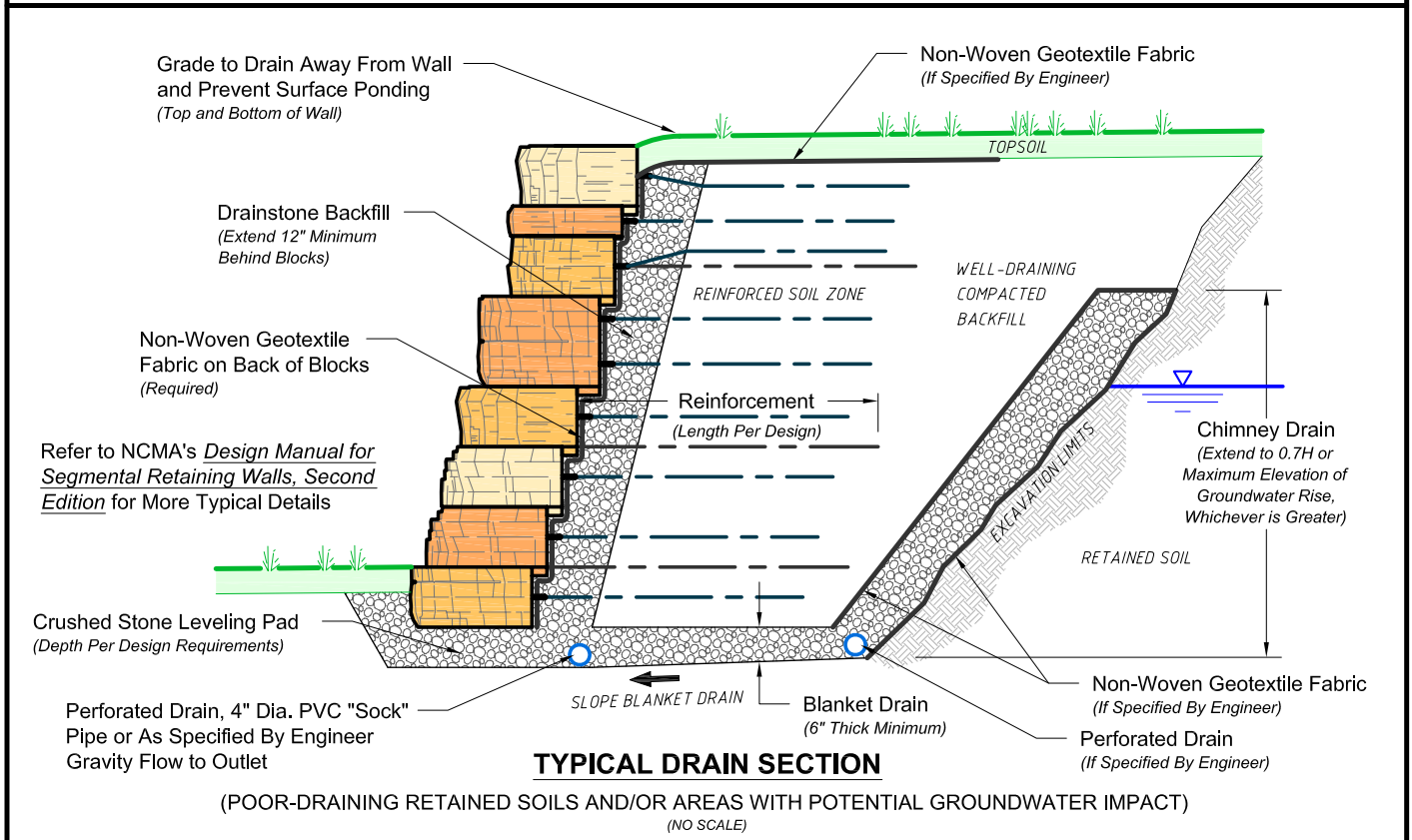
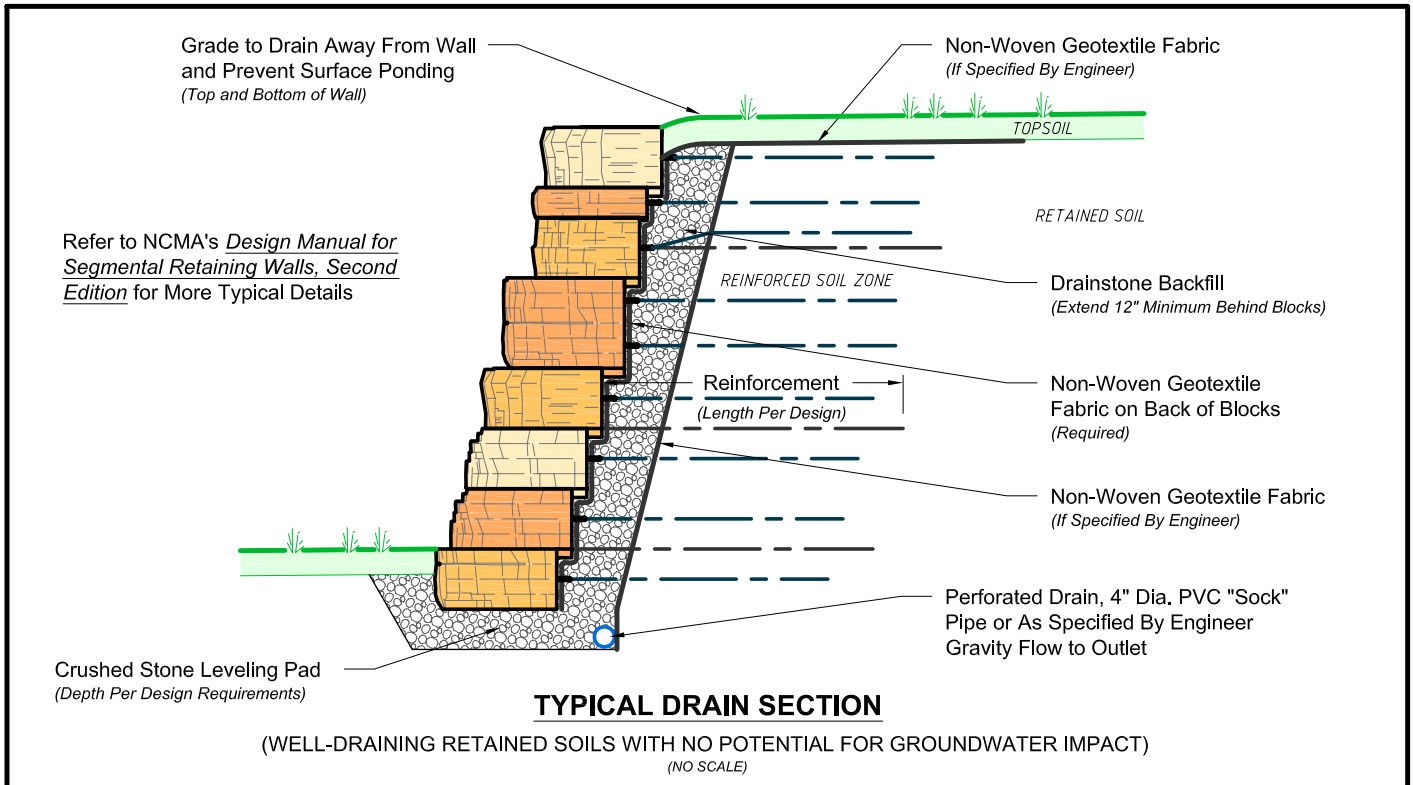

DRAWN BY: J. Johnson	TITLE: TYPICAL DRAIN DETAILS
APPROVED BY:	
DATE: January 28, 2008	DRAWING FILE: Drain Options - Typical Reinf Wall Details.dwg

ROSETTA
HARDSCAPES, LLC

05481 US 31 SOUTH CHARLEVOIX, MI 49720
877-777-6558 • 231-237-9656 Fax • www.discoverrosetta.com

SIDE VIEWS OF DIFFERENT HEIGHT BLOCKS

(NO SCALE)

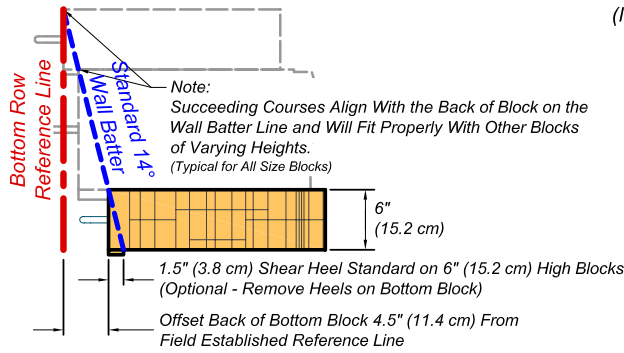

6" (15.2 cm) HIGH BLOCKS

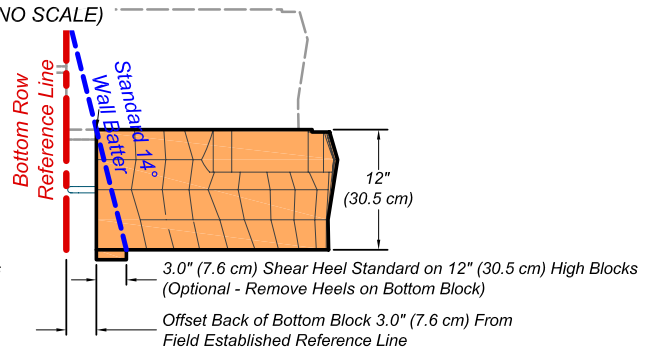

12" (30.5 cm) HIGH BLOCKS

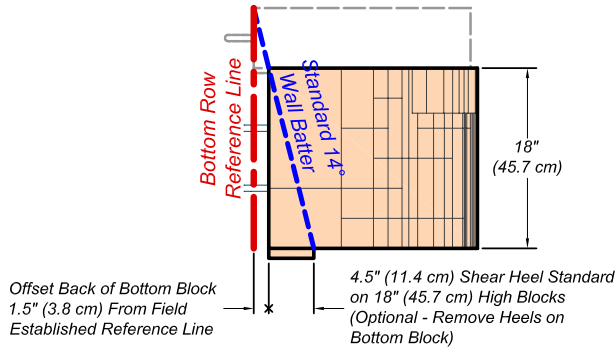

18" (45.7 cm) HIGH BLOCKS

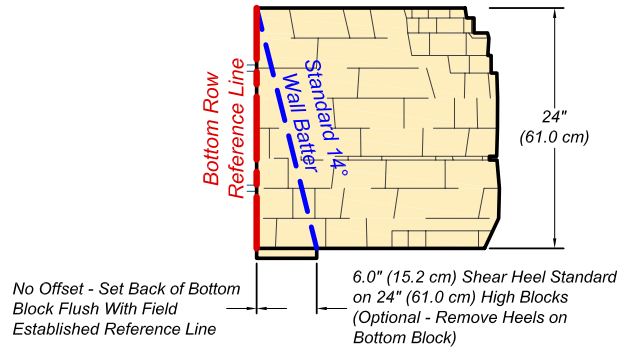

24" (61.0 cm) HIGH BLOCKS

TOP VIEWS OF DIFFERENT HEIGHT BLOCKS

(NO SCALE)

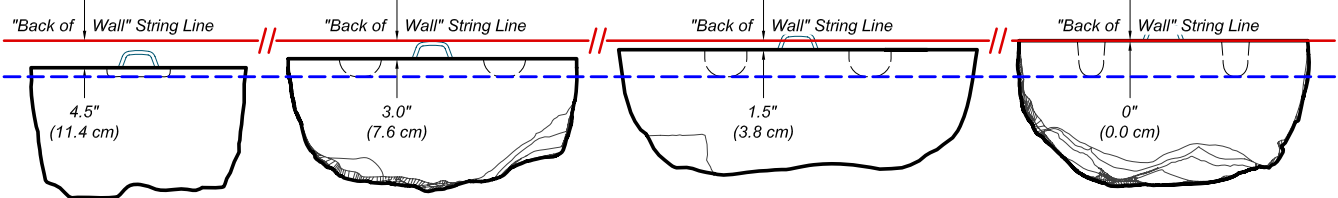

6" (15.2 cm) HIGH BLOCKS
Offset Back of Block 4.5" (11.4 cm) From String Line

12" (30.5 cm) HIGH BLOCKS
Offset Back of Block 3.0" (7.6 cm) From String Line

18" (45.7 cm) HIGH BLOCKS
Offset Back of Block 1.5" (3.8 cm) From String Line

24" (61.0 cm) HIGH BLOCKS
Set Back of Block Flush With String Line

(Note that when the bottom blocks are properly offset, the front of the shear heels are all lined up as if there were another course of blocks beneath the starting course.)

PROSPECTIVE VIEW OF BACK OF WALL

(NO SCALE)

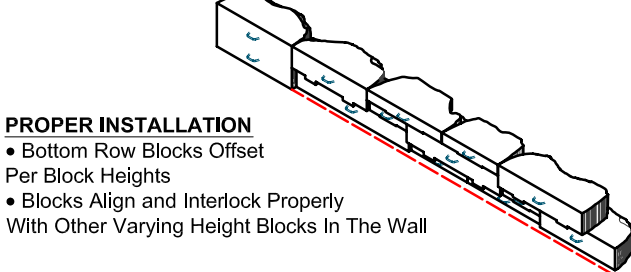

PROPER INSTALLATION

- Bottom Row Blocks Offset Per Block Heights
- Blocks Align and Interlock Properly With Other Varying Height Blocks In The Wall

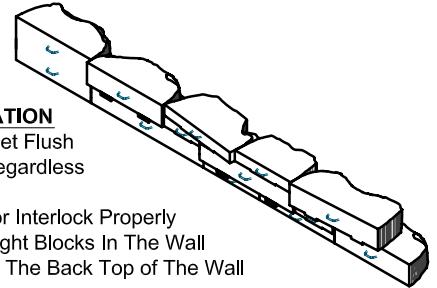

IMPROPER INSTALLATION

- Bottom Row Blocks Set Flush With The Same Line Regardless of Block Heights
- Blocks Do Not Align or Interlock Properly With Other Varying Height Blocks In The Wall
- Note Irregular Line At The Back Top of The Wall

DRAWN BY: J. Johnson	TITLE: PROPER BOTTOM ROW INSTALLATION FOR ROSETTA HARDSCAPES BLOCKS
APPROVED BY:	
DATE: February 29, 2008	DRAWING FILE: Bottom Row Block Installation.dwg

ROSETTA
HARDSCAPES, LLC
05481 US 31 SOUTH CHARLEVOIX, MI 49720
877-777-6558 • 231-237-9656 Fax • www.discoverrosetta.com

STEPS

STEPS
5½" RISE

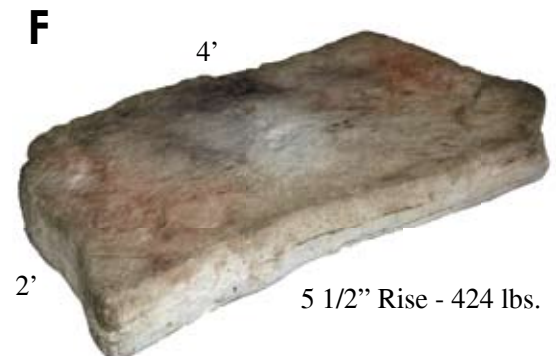

Colors may vary from colors shown • All Weights are approximate

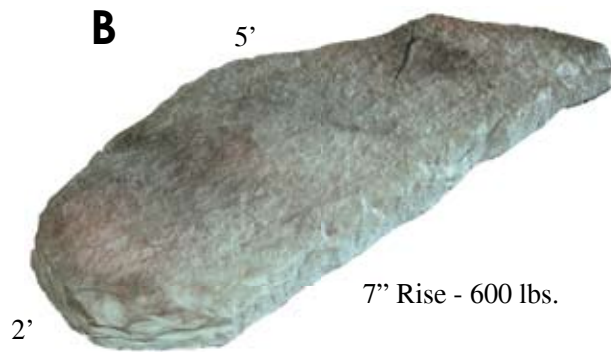
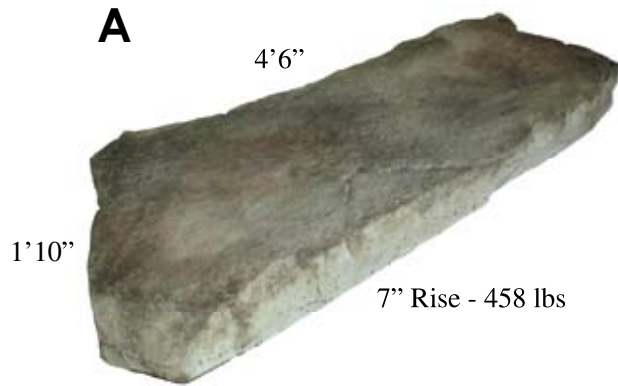

Colors may vary from colors shown • All Weights are approximate

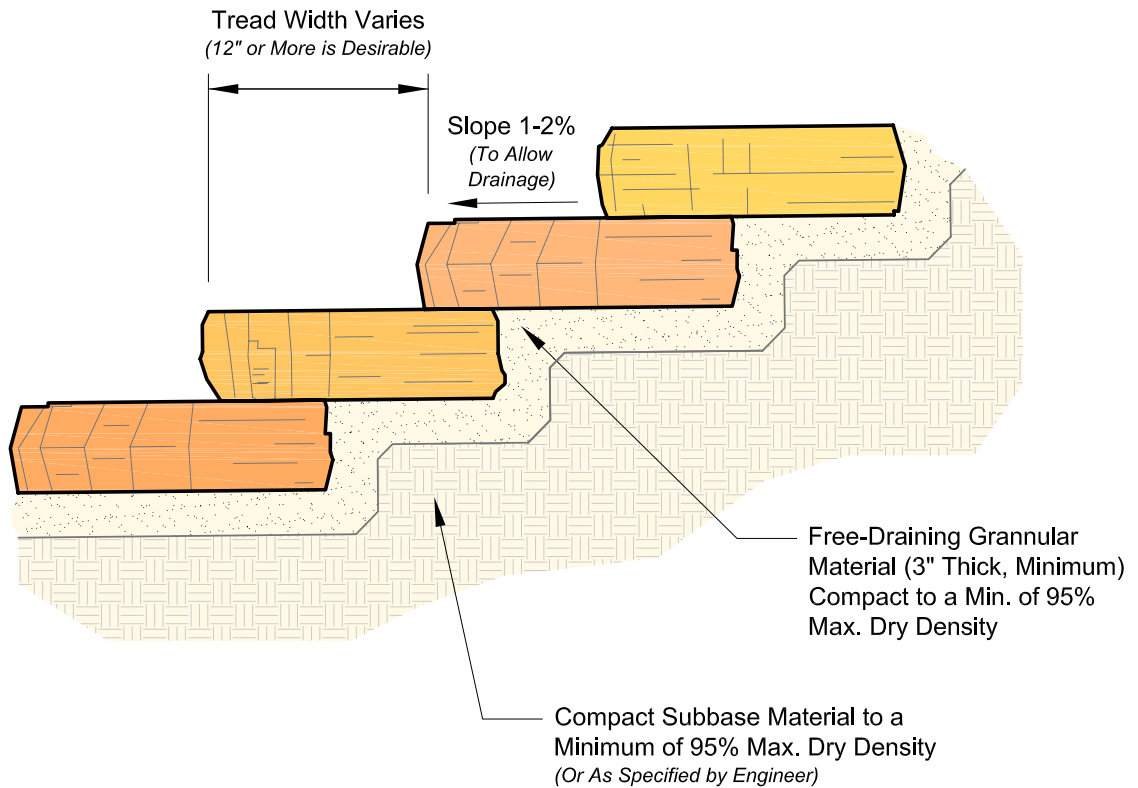

TYPICAL STEP INSTALLATION

(NO SCALE)

DRAWN BY: J. Johnson
APPROVED BY:
DATE: January 25, 2008

TITLE: TYPICAL ROSETTA HARDSCAPES STEP INSTALLATION
DRAWING FILE: Step Installation - Typical Section.dwg

ROSETTA
HARDSCAPES, LLC

05481 US 31 SOUTH CHARLEVOIX, MI 49720
877-777-6558 • 231-237-9656 Fax • www.discoverrosetta.com

ACCENTS





INSTALLATION





Thank you for your interest in installing Rosetta's premium line of hardscape products. You will find that no other engineered system offers the *natural beauty*, the *design flexibility*, and the *structural stability* of the Rosetta system. This installation brochure will give you the fundamental knowledge needed to construct *stunning, quality* retaining walls and landscape step systems that will last for generations to come.

www.discoverrosetta.com



Pre-Construction:

Before you start construction, take the time to complete the necessary planning and preparation. This process will keep your project running efficiently and will aid in completing a quality installation. Make sure to address the following:

Develop a project safety plan. Be sure to follow all applicable governmental (ie. OSHA) standards. Be sure to address items such as: personal protective equipment, maintaining safe slopes, fall protection, rigging and lifting, and any other safety precautions.

Attain the necessary permits and engineering.

Review the project plans. Make sure that the plans take into account current site and soil conditions. Clays or poor soils place significantly greater loads on walls than free draining aggregates. If poor soils are present, make sure the plans account for them.

Develop a plan to control surface water during construction.

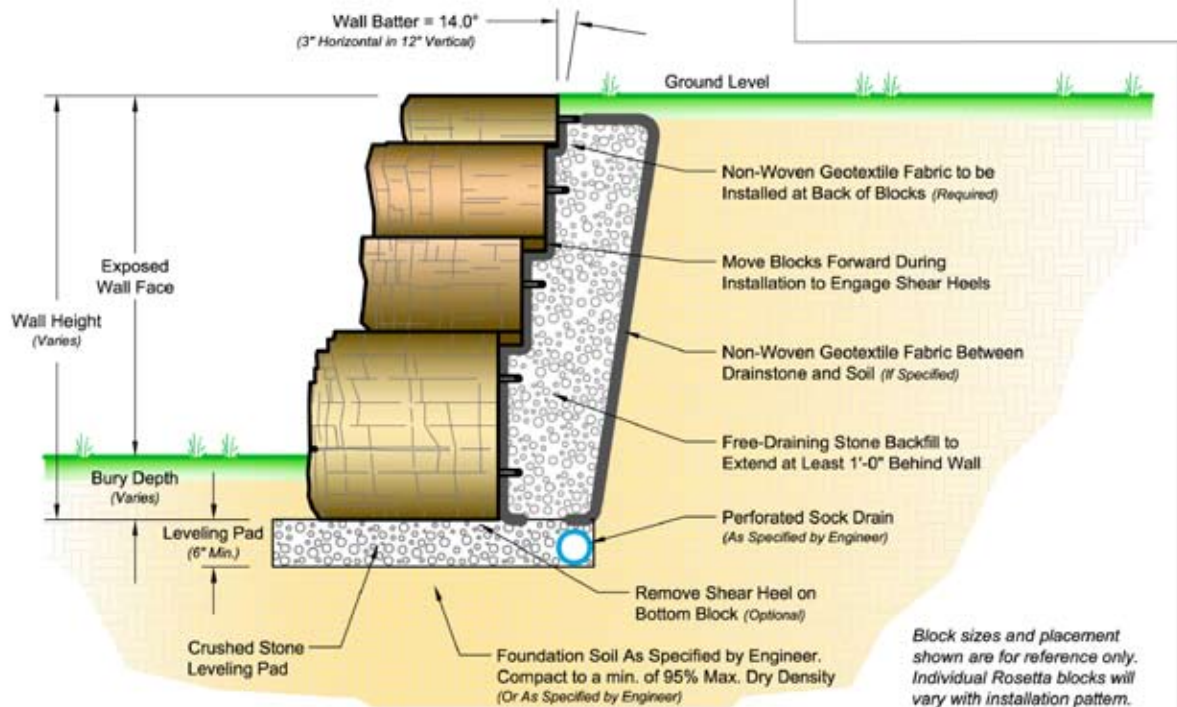

Step 1. Base Preparation

Proper base preparation is one of the most critical elements of retaining wall construction. The retaining wall is only as stable as the foundation it is placed on. If sub-base soils are deemed unstable, contact a qualified geotechnical engineer for remediation.

First, **excavate for the leveling pad**. The minimum leveling pad thickness is 6". Higher walls may require a thicker leveling pad based on the detailed wall design. The leveling pad should be a minimum of 40" wide, or wider if called for in the engineered construction drawings. The sub grade material needs to be compacted to 95% of standard proctor maximum density.

Place 4" perforated sock drain at the back of the excavated trench. Make sure drain has a long term gravity outlet (either to daylight or to approved catch basin).

Place clean crushed stone into excavated trench. Level and compact stone to the design thickness. Check level with a laser or transit. Note: Take time to make sure the base is accurately leveled. This will allow the wall to be installed much more efficiently.



Step 2. Place Bottom Course

Proper placement of the bottom course of wall stones is critical in determining the overall appearance and integrity of the finished project. Take extra time on this step and the rest of the project will go smoothly. At this point you need to **determine the best point of origin for the wall**. If you have a fixed point, such as a building corner or a 90° corner, you will want to start the wall from that point and work your way out. This will minimize cutting of blocks. If there are no fixed points, start the wall at the lowest design elevation, as it is easier to step the base up than it is to step the base down.

Nearly all segmental block wall systems have a built in batter to provide greater wall stability. With Rosetta, the batter is 14 degrees, which equals 3" of setback for every vertical foot up.

One of the unique features of the Rosetta system is multiple block heights. To provide a uniform wall batter with multiple height blocks, the setback of the blocks varies proportionally with the block height. The setback in blocks is achieved with shear heels which are cast into the Rosetta blocks. For a 6" high block, the shear heels are 1.5" deep (1/2 times 3"). For a 12" high block, the shear heels are 3" deep (1 times 3"). For a 24" high block, the shear heels are 6" deep (2 times 3").

To ensure proper wall alignment and to account for the multiple height blocks and varying setbacks, you have to adjust the bottom row of blocks based on their height. Setup a traditional string line for the back of the wall, then offset the blocks per the following:

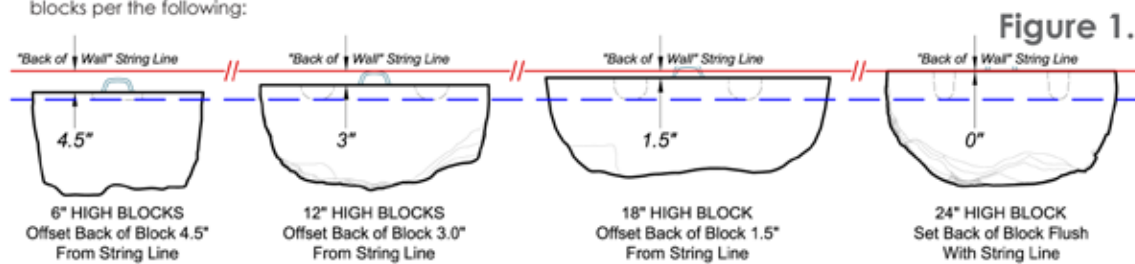

When you follow this simple step, the bottom blocks are properly placed and the rest of the wall stacks up straight and true.

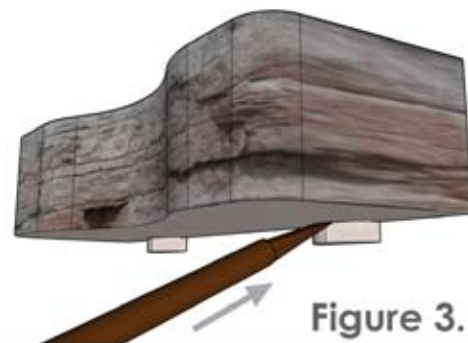
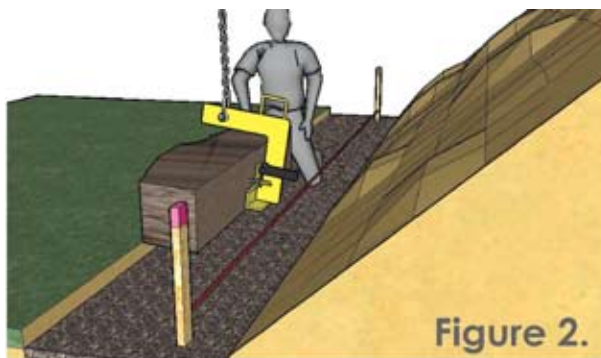

You may find it useful to **remove the shear heels from the blocks to be placed on the bottom course**. This can be done using a demolition bar. (see **Figure 3.**) Be sure to do this in a safe manner, keeping your body away from potential falling hazards.

Using an appropriately rated skid steer or small excavator and the Rosetta Lifting Device, **place each block along the string line according to Figure 1**. Be sure that the safety latch on the Lifting Device is engaged before lifting each block. Use a bar to make small adjustments to bring the blocks into line.

After placing each block, **check for level both front to back and side to side**. If the block is out of level, either pick up the block and correct the base material, or tap it into place using the setting machine and a block of wood (to avoid marring the wall stone).

Continue following the above procedures until the entire course of wall stones has been placed.

Step 3. Place Upper Courses

Placing the next course of blocks is similar to placing the first course. The primary difference is that you must **engage the shear heels of the upper blocks with the backs of the lower blocks.**

Position the clevis in the Rosetta Lifting Device in such a way that the front of the block is slightly higher than the back of the block.

Hold each block behind and approximately 1/2" above the block below.

Swing the block toward the face of the block below until both shear heels engage.

Set the block down and make final adjustments with a large pry bar. Do not leave any gaps between blocks unless you are constructing a planter pocket.



Step 4. Backfill

Appropriate selection and placement of backfill is necessary for the structural integrity of the wall. **Place only backfill materials which are consistent with the wall design. For safety reasons, do not stack wall stones more than two feet high before backfilling.**

Before placing backfill materials, **place a layer of non-woven geotextile fabric behind the blocks.** This will keep materials from eroding through the small voids between the blocks.

Place clean stone a minimum of one foot behind the wall. This creates a continuous drainage course for any water to rapidly reach the drain pipe. Hydrostatic pressure is the number one cause of retaining wall failure. This step is critical in keeping backfill materials dry and structurally sound.

Beginning at the back of the clean stone and working away from the wall, **place and spread backfill soils.**

Compact soils in lifts of appropriate depth for the compaction equipment being used (typically 4-12"). Backfill materials must be compacted to 95% Standard Proctor. Generally, you should operate compaction equipment parallel to the face of the wall. Start at the back of the blocks, and work your way away from the wall until you reach undisturbed soils. Continue placing and compacting backfill materials until you approximately reach the top of the upper course of blocks.

Repeat steps three and four until you have reached finish grade for the wall.

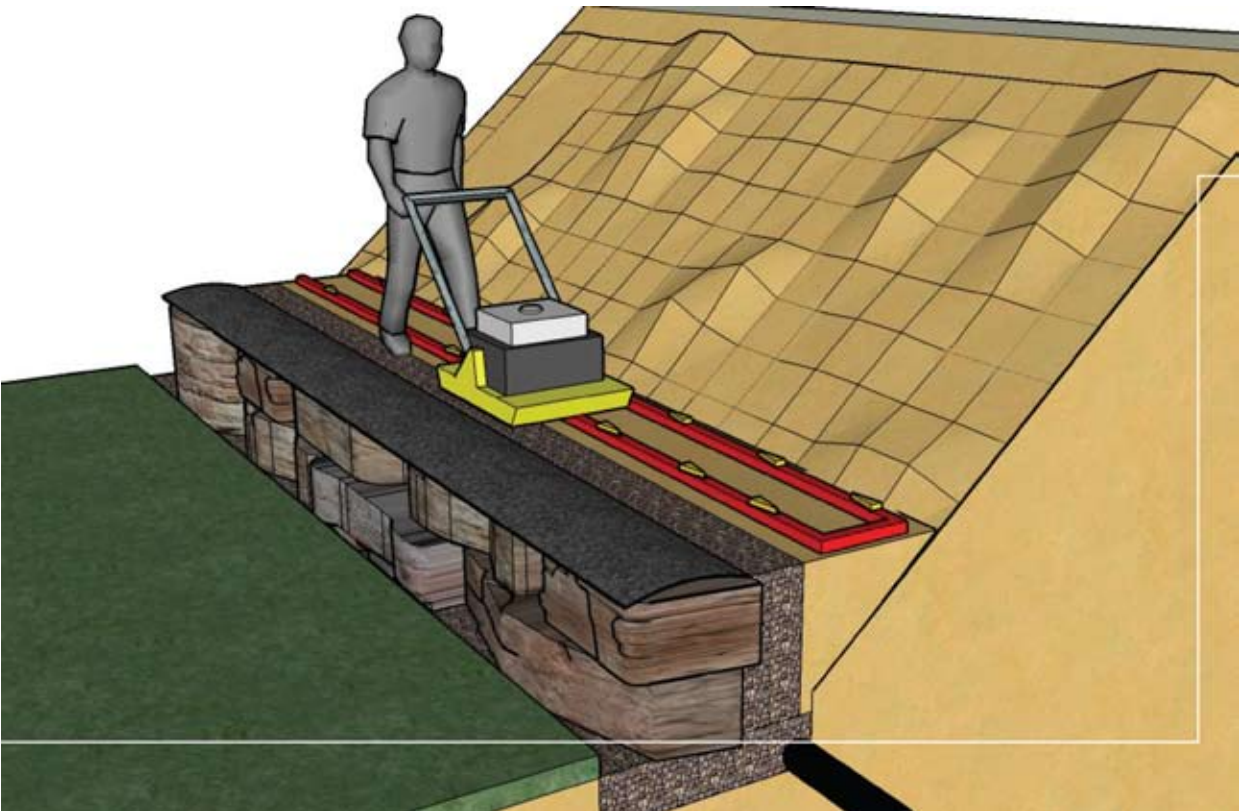

Step 5. Finishing The Wall

Completing a few simple tasks near the end of the project will ensure that the wall will function properly and look good for years to come.

Make sure that the drain pipe is tied into a catch basin or run to a long term daylight opening. If you are using flexible drainpipe behind the wall, convert it to Schedule 40 PVC or equivalent before outleting from behind the wall. This will insure that the pipe is not easily crushed during future construction.

Place non-woven geotextile fabric over the clean stone. You may need to leave the clean stone down 4" to 6" from the top of the wall to allow for landscape or other materials.

Grade the top of the wall in such a way that water runs off away from the wall. Never leave the top of a wall graded where surface water will pond behind the wall. If future grading is to take place by others, you should have a responsible party sign off regarding this point.

FINISHING OPTIONS



Plant appropriate vegetation on the back of the wall



Use Rosetta steps as top blocks, especially when the grade falls away at the ends of the wall



Place pavers flush with the back of the Rosetta Blocks



Grade slope to rise above top blocks, giving the look of **natural outcropping** in the bank. (Design must account for surcharge loading)



Other Applications



Step Installation:

Begin the step installation process by measuring the total rise required and calculating the number of steps to be used. Each step has a 5½" or 7" rise, but should be sloped approximately ½" such that the back of the step is higher than the front of the step. This sloping will facilitate surface water drainage. With appropriate sloping, the net rise of each step is 6" or 7½". Divide the total rise by 6" or 7½" to get the number of steps required.

Next, **calculate the tread width**. Generally, when the grade allows, a 12" or wider tread is desirable. To calculate the tread width, divide the total allowable horizontal run minus the width of the top step, by the number of steps minus one. The one less will account for the top step.

Consider the following example:

Total rise = 42", Total horizontal run = 108", Width of top step = 24", Rise of steps = 5½", Number of steps = $42" \div 6" / \text{Step} = 7 \text{ Steps}$
Tread Depth = $(108" - 24") \div (7 - 1) = 14" \text{ Tread Depth}$

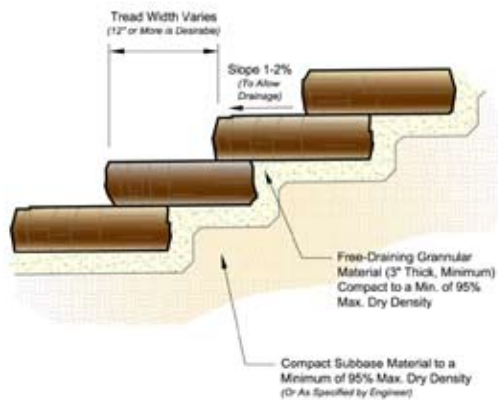

Excavate and grade the area for first step. Steps should be placed on at least 3" of free draining soil, such as sand or pea-stone. Compact soil to a minimum of 95% Standard Proctor.

Place step with either forks or straps using a small excavator or skid-steer to lift the piece into place. Practice safe handling procedures during this process.

Fill behind each step with free draining soil and compact to 95% standard proctor. Remember to slope fill to allow for proper drainage when next step is placed. Continue placing steps in this manner until finish grade is reached.



Pallet A: 18 ft.²
4000 lbs.



12" x 3' 6"



12" x 4'



12" x 5'

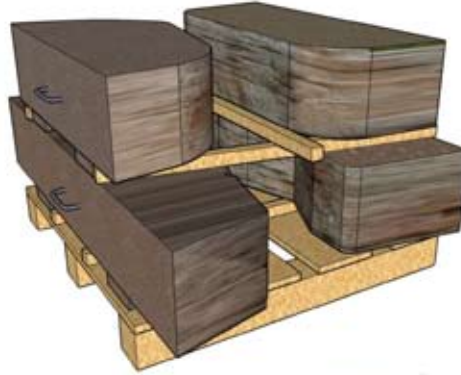

12" x 5' 6"

Note: Color, texture and shape may vary.

Pallet B: 18 ft.²
4000 lbs.



6" x 2'



6" x 3'



12" x 3'



6" x 4'



12" x 4' 6"



12" x 6'

Note: Color, texture and shape may vary.

Pallet C: 18 ft.² 4000 lbs.



18" x 5'



24" x 4'



6" x 2'



6" x 3'

Note: Color, texture and shape may vary.

Steps

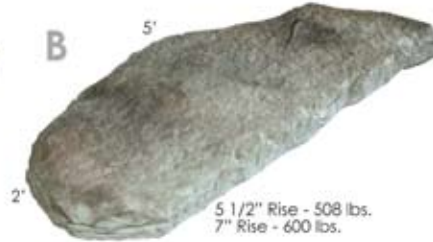

Note: Color, texture and shape may vary.

*All Dimensions Nominal

Sample Patterns:



2' x 45'

One of the great advantages of the Rosetta system is the ability of a designer or a contractor to lay out a wall in advance, saving time and effort during installation. The following patterns can be used to aid in wall lay-out and design. Each pattern is 90 square feet and uses 2 A Pallets, 2 B Pallets, and 1 C Pallet. Rosetta custom layout and design software is also available on our website. Please visit www.discoverrosetta.com and click on the DESIGN link.

3' x 30'

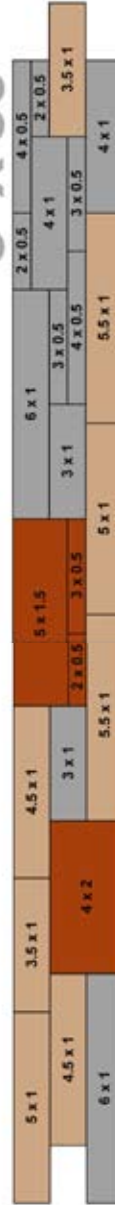

Sample Patterns:

